

# LIPOSORBER<sup>®</sup> LA-15 SYSTEM

---

**Operator's manual for use in the treatment of pediatric patients with primary focal segmental glomerulosclerosis (FSGS)**

**Humanitarian Use Device**

Authorized by Federal (USA) law for use in the treatment of pediatric patients with nephrotic syndrome associated with primary focal segmental glomerulosclerosis (FSGS) when:

- Standard treatment options, including corticosteroid and/or calcineurin inhibitors, are unsuccessful or not well tolerated and the patient's glomerular filtration rate (GFR)  $\geq 60$  ml/min/1.73 m<sup>2</sup> or
- The patient is post renal transplantation.

The effectiveness of this device for this use has not been demonstrated.

**Caution:** Federal law restricts this device to sale by or on the order of a physician.

**Important:**

Be sure to carefully read this operator's manual before use.  
Keep this manual by the machine for immediate reference.

This manual is applicable to the KANEKA MA-03 with the software version 1.2.  
The software version is displayed on the KANEKA MA-03's screen.

KANEKA PHARMA AMERICA LLC  
NEW YORK, NY

2013-xx

# FOREWORD

---

## • ABOUT THE LIPOSORBER® LA-15 SYSTEM OPERATOR'S MANUAL



### NOTICE

This manual is applicable to the KANEKA MA-03 with the software version 1.2.

Confirm that the model of the machine and the software version described in this manual correspond to those in the machine to be used.

1. The model of the machine is described in the rating plate on the rear panel.
2. The software version is displayed on the LCD screen of the operation panel.

Maintenance mode menu screen is displayed on the LCD screen by touching the Maintenance mode key in the bottom area of the LCD screen.

Machine information screen opens by touching the Machine information key, and the software version is displayed on the LCD screen.

Manual No.	Software version
No.870en-Rx	Ver.1.2

This Operator's Manual contains the information needed to operate the LIPOSORBER® LA-15 System correctly and safely. It is essential that you read this manual carefully and be sure you understand it before you operate the LIPOSORBER® LA-15 System. Pay particular attention to the Cautions and Warnings and to the items indicated by the safety alert symbol

## • COMMENTS OR QUESTIONS

All reasonable efforts have been made to assure the accuracy of the contents of this Operator's Manual. If you have any comments or questions regarding this manual or any questions that are not answered in this manual, contact Kaneka Pharma America LLC.

Kaneka Pharma America LLC  
546 Fifth Avenue; 21st Floor  
New York, NY 10036

Telephone: (877) 526-5269  
Fax: (212) 705-4350

## • ABOUT THE SAFETY ALERT SYMBOL

The safety alert symbol  identifies situations that could be dangerous to the operator or the patient and directs your attention to the proper operation of the Apheresis Machine KANEKA MA-03 (hereinafter the MA-03). Read and understand each Warning, Caution and Notice thoroughly. See the next page of this manual for an explanation of these safety alerts.

This manual is copyrighted by Kaneka Pharma America LLC and no part of it should be reprinted without Kaneka Pharma America LLC's prior permission.

---

This operator's manual is intended to be a reference for proper and safe operation of the MA-03. In no way is this manual intended to be a step-by-step guide in the actual decisions regarding the treatment of the patients.

For proper and safe operation, be sure to carefully read this operator's manual before use. Keep this manual by the machine for immediate reference.

## Symbols and Remarks for Safety

In this manual and on each MA-03, the following safety symbols and remarks are shown for safe and proper use of the equipment.

The meanings of the symbols are as follows.

Familiarize yourself with the meanings of the symbols before reading the text of the manual.



**DANGER** indicates an imminently hazardous situation which, if not avoided, will result in death or serious injury.



**WARNING** indicates a potentially hazardous situation which, if not avoided, may result in death or serious injury.



**CAUTION** indicates a potentially hazardous situation which, if not avoided, may result in minor or slightly injury.



**NOTICE** indicates practices you must know when operating the machine, although the situation may not be as serious as those mentioned above.

## • COMPONENTS

The LIPOSORBER® LA-15 System is an integrated, automated extracorporeal blood processing system that includes the following 3 disposables and a control/monitor machine:

LIPOSORBER® LA-15 LDL Adsorption Column set (disposable) consisting of two columns, each containing 150 ml of dextran sulfate cellulose adsorbent;

SULFLUX® KP-05 Plasma Separator (disposable) containing hollow fibers made of polyethylene coated by an ethylene-vinyl alcohol copolymer;

Tubing System for Plasmapheresis (NK-M3R(U)) (disposable); and

the Apheresis Machine KANEKA MA-03, which monitors and controls the LDL-apheresis procedure.

## • PRINCIPLES OF OPERATION

### The LIPOSORBER® LA-15 System

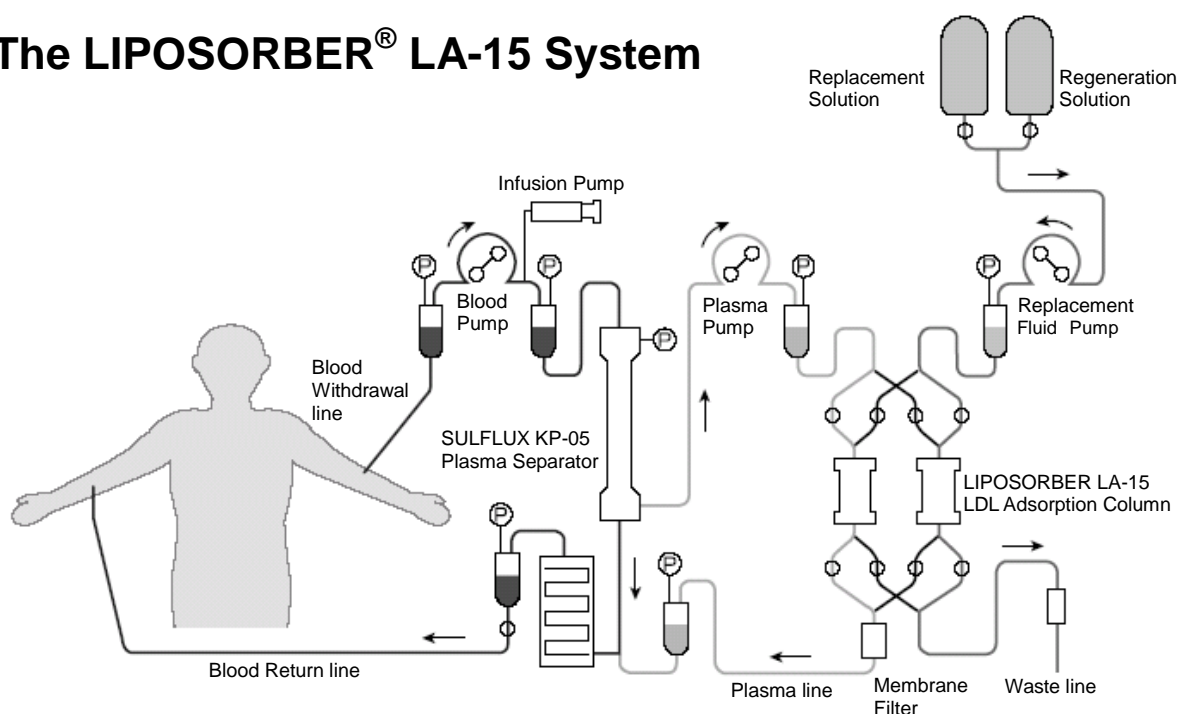

Figure A. LIPOSORBER® LA-15 System overview.

As illustrated in Figure A, the patient's blood is withdrawn via a venous access connected to the blood withdrawal line and enters the plasma separator. As blood flows into the top of the separator, through the hollow fibers, plasma is separated and exits from the separator side outlet. The remaining blood, including red and white blood cells and platelets, exits from the separator bottom outlet. The cell-free plasma enters the top inlet of one of the two LDL adsorption columns. As the plasma passes through the column, the apolipoprotein B-containing lipoproteins - LDL, VLDL, and Lp(a) - are selectively adsorbed in the column. There is minimal effect on HDL and other plasma components. The LDL-depleted plasma exits the adsorption column bottom outlet, flows through the membrane filter, is recombined with the blood cells exiting the separator bottom outlet and is returned to the patient via venous access.

When the first 500 ml of plasma has been treated with the left column, the MA-03 automatically switches the plasma flow to the right column. At this point, the plasma exiting the

plasma separator flows into the right column, while the plasma remaining in the left column is pushed out with 140 ml of replacement solution (Lactated Ringer's Injection, USP) and returned to the patient.

When recovery of the plasma from the left column is completed, the plasma return line is switched over from the left column to the right column, enabling the plasma in the right column to return to the patient. Throughout this column switch-over operation, the replacement fluid pump is automatically operated at the same speed as the plasma pump. The replacement solution during each switch-over is not returned to the patient.

While the right column is still treating plasma, the left column is rinsed with 105 ml of regeneration solution (5% Sodium Chloride Injection, USP), and its original adsorption capacity is restored. Along with the regeneration solution, apolipoprotein B-containing lipoproteins LDL, VLDL, and Lp(a) are flushed from the column through the waste line into the waste bag. When elution is completed, 355 ml of replacement solution is pumped through the column to rinse out the regeneration solution completely and re-prime the column. The column is now ready for the next cycle of adsorption.

Subsequent switch-over and regeneration cycles are repeated every time 600 ml of plasma has been treated by one of the two LDL adsorption columns, allowing continuous LDL-apheresis until the predetermined plasma volume has been treated. The first switch-over occurs at 500 ml because initial levels of LDL, VLDL, and Lp(a) are higher in the first cycle.

The tubing system, plasma separator and two LDL adsorption columns, are intended for single use only. All disposables must be discarded after each procedure.

# CONTENTS

---

## 1. INTRODUCTION

1.1	Description	1-1
1.2	Indications for Use	1-2
1.3	Contraindications	1-3
1.4	Patient Selection	1-4
1.5	Warnings	1-5
1.6	Precautions	1-7
1.7	Adverse Events	1-9
1.8	Clinical Data	1-11
1.9	Instructions for Use	1-13
1.9.1	Determining Plasma Volume to be treated	1-13
1.9.2	Determining Heparin Dosage	1-13
1.10	Moving and Transportation of the MA-03	1-15
1.10.1	Moving of the MA-03 Indoors	1-15
1.10.2	Transportation of the MA-03 Outdoors	1-16
1.11	EMC information	1-17
1.11.1	Electromagnetic Emission and Electromagnetic Immunity	1-17
1.11.2	Recommended separation distances between portable and mobile RF communications equipment and the MA-03	1-20
1.12	The MA-03 DANGER, WARNING, AND CAUTION	1-21
1.13	Limits to the Manufacturer's Responsibility	1-26

## 2. OVERVIEW OF THE MA-03

2.1	Environmental Conditions	2-1
2.2	Configurations of the MA-03	2-2
2.2.1	Appearance	2-2
2.2.2	Monitor/Operation Panel	2-6
2.2.3	Front Panel	2-8
2.2.4	Blood Pump, Plasma Pump, and Replacement Fluid Pump	2-10
2.2.5	Infusion Pump	2-11
2.3	Specifications	2-12
2.3.1	Dimensions and Weight	2-12
2.3.2	Electric Safety (Classified According to EN / IEC60601-1)	2-12
2.3.3	Power Supply	2-13
2.3.4	Fuses (Power Unit)	2-13
2.3.5	Monitoring Parts	2-14
2.3.6	Actuators	2-18
2.4	Disposable Parts	2-20
2.4.1	Adsorption Column	2-20
2.4.2	Blood Tubing	2-20
2.4.3	Plasma Separator	2-20
2.4.4	Syringe for Infusion Pump	2-20
2.5	Environmental Issues	2-21

# CONTENTS

---

<b>3. TREATMENT METHOD OF THE MA-03</b>	
3.1 Applicable Treatment .....	3-1
3.2 Plasma Adsorption Treatment .....	3-2
3.2.1 Overview of PA2 .....	3-2
3.2.2 Action of PA2 .....	3-3
3.3 Operation Flow .....	3-5
<b>4. DISPLAY SCREEN OF THE MA-03</b>	
4.1 Screen Section .....	4-1
4.2 Operation Area .....	4-2
4.2.1 Main Keys in "Operation Area" .....	4-2
4.2.2 Operational State Screen .....	4-4
4.3 Function Keys Area .....	4-4
4.4 Status Area .....	4-5
<b>5. DATA SETTING OF THE MA-03</b>	
5.1 Basic Setting Procedure .....	5-1
5.1.1 Numeric keypad .....	5-1
5.1.2 Basic Methods of Data Input .....	5-2
5.2 Data List .....	5-4
5.2.1 Treatment data setup .....	5-4
5.2.2 Facility data setup .....	5-5
<b>6. TREATMENT OPERATION OF THE MA-03</b>	
6.1 Machine Preparation .....	6-1
6.1.1 Turning on the Machine .....	6-1
6.1.2 Testing the Machine .....	6-2
6.1.3 Selecting the Treatment Method .....	6-5
6.2 PA2 .....	6-7
6.2.1 Install Tubing .....	6-7
6.2.2 Rinsing and Priming .....	6-19
6.2.3 Treatment .....	6-26
6.2.4 Return .....	6-31
6.2.5 Completion of the Operation .....	6-33
6.2.6 Completion .....	6-33

# CONTENTS

---

## 7. ALARMS OF THE MA-03

7.1	Alarm Status	7-1
7.2	Alarm display	7-2
7.3	Alarm point about pressure	7-4
7.4	Troubleshooting	7-5
7.5	The recovery procedure to an alarm	7-7
7.5.1	Alarm related to Treatment	7-7
7.6	Manual Blood Return	7-15
7.7	Alarm list	7-16
7.7.1	Alarm related to Treatment (TRxxx)	7-16
7.7.2	Function check alarm (FCxxx)	7-18
7.7.3	Information (DMxxx)	7-29

## 8. DATA RECORD FUNCTION OF THE MA-03

8.1	Alarm history	8-1
8.1.1	Outline	8-1
8.1.2	The display method	8-1
8.2	Graph display	8-2
8.2.1	Outline	8-2
8.2.2	The display method of pressure graph	8-2
8.3	Data logging	8-4
8.3.1	Outline	8-4
8.3.2	Corresponding card	8-4
8.3.3	The data classification and items which are recorded	8-5
8.3.4	The method of operation	8-8
8.3.5	File management	8-10

## 9. MAINTENANCE AND INSPECTION OF THE MA-03

9.1	Care	9-2
9.1.1	Cleaning the Surface	9-2
9.2	Inspection Before Use	9-3
9.2.1	Prior to Turning Power On	9-3
9.2.2	After Turning Power On	9-3
9.3	Check during operation and after use for;	9-4
9.4	Maintenance of the System	9-4

## 10. OPERATION SWITCH-OVER TIMETABLE

## 11. PUMP FLOW RATE REGULATION DURING OPERATION & RETURN OF THE MA-03

11.1	Restrictive Pressure Limits Affecting Pump Flow Rate	11-1
11.2	Restrictive Pressure Display For Pump Flow Rate	11-2

## 12. EXTRACORPOREAL VOLUMES



# CONTENTS

---

**13. TECHNICAL INFORMATION OF THE MA-03**

- 13.1 Specifications .....13-1
- 13.2 Electrical Conditions..... 13-1
- 13.3 Required Environmental Conditions.....13-2

**APPENDIX A**

Abbreviations and Symbols of the MA-03

# 1. INTRODUCTION

---

This operator's manual is intended to be a reference for proper and safe operation of the MA-03. In no way is this manual intended to be a step-by-step guide in the actual decisions regarding the treatment of the patients.

For proper and safe operation, be sure to carefully read this operator's manual before use. Keep this manual by the machine for immediate reference.

## 1.1 DESCRIPTION

The LIPOSORBER® LA-15 System is an integrated, automated extracorporeal blood processing system that includes the following 3 disposables and a control/monitor machine:

LIPOSORBER® LA-15 LDL Adsorption Column set (disposable) consisting of two columns, each containing 150 ml of dextran sulfate cellulose adsorbent;

SULFLUX® KP-05 Plasma Separator (disposable) containing hollow fibers made of polyethylene coated by an ethylene-vinyl alcohol copolymer;

Tubing System for Plasmapheresis (NK-M3R(U)) (disposable); and

the Apheresis Machine KANEKA MA-03, which monitors and controls the LDL-apheresis procedure.

All of the above components are authorized by Federal law for use in the treatment of pediatric patients with primary focal segmental glomerulosclerosis (FSGS).

**Caution: Federal law restricts this device to sale by or on the order of a physician.**

This system may be used only as prescribed by a licensed and appropriately trained physician. While connected to the extracorporeal system, the patient must be attended at all times by a physician or qualified health-care professional adequately trained in all aspects of the procedure. All physicians and medical personnel utilizing the LIPOSORBER® LA-15 System **will be required** to have completed an appropriate training program.

## 1.2 INDICATIONS FOR USE

### Humanitarian Use Device

Authorized by Federal (USA) law for use in the treatment of pediatric patients with nephrotic syndrome associated with primary focal segmental glomerulosclerosis (FSGS) when:

- Standard treatment options, including corticosteroid and/or calcineurin inhibitors, are unsuccessful or not well tolerated and the patient's glomerular filtration rate (GFR)  $\geq 60$  ml/min/1.73 m<sup>2</sup> or
- The patient is post renal transplantation.

The effectiveness of this device for this use has not been demonstrated.

The LIPOSORBER® LA-15 System is indicated for use in the treatment of pediatric patients with nephrotic syndrome associated with primary focal segmental glomerulosclerosis when:

- Standard treatment options, including corticosteroids and/or calcineurin inhibitor treatments, are unsuccessful or not well tolerated and the patient's glomerular filtration rate (GFR)  $\geq 60$  ml/min/1.73 m<sup>2</sup> or
- The patient is post renal transplantation.

## 1.3 CONTRAINDICATIONS

This device must not be used in:

- (a) patients who have been treated with ACE-inhibitors within the past 24 hours;

Severe anaphylactoid reactions including shock have been observed in patients treated with the Liposorber® LA-15 under concomitant ACE-inhibitor medication. The risk of an anaphylactoid reaction may be minimized by withholding the administration of ACE inhibitors for approximately 24 hours before each LDL-apheresis procedure. The time period to withhold ACE inhibitors should be prolonged, if determined by the treating physician, considering each individual's renal function and the biological half-life of the ACE-inhibitor currently in use. If required, ACE-inhibitor administration may be resumed on the day of the apheresis treatment but only after the apheresis treatment is complete.

- (b) patients for whom adequate anticoagulation cannot be achieved, such as those with severe hemophilia, severe hemorrhage diathesis, severe gastrointestinal ulcers, or who are receiving vitamin K antagonist medications after surgery;
- (c) patients for whom extracorporeal circulation therapy with Liposorber® LA-15 cannot be tolerated such as those with severe cardiac insufficiency, acute myocardial infarction, severe cardiac arrhythmia, acute apoplexy, or severe uncontrollable hypertension or hypotension; and
- (d) patients with hypersensitivity to dextran sulfate cellulose, heparin or ethylene oxide.

## 1.4 PATIENT SELECTION

The following patients may benefit from the LIPOSORBER® LA-15 System. The following are intended only as guidelines for appropriate patient selection:

- Pediatric patients with glomerular filtration rate (GFR)  $> 60$  ml/min/1.73 m<sup>2</sup> and a history of primary FSGS accompanied by refractory or recurrent nephrotic syndrome defined as:
  - Patients unresponsive to standard corticosteroid and/or calcineurin inhibitor therapy for at least 8 weeks resulting in failure to achieve complete or partial remission
  - or*
  - Patients intolerant to standard therapies due to severe side effects which negatively affect quality of life without providing an acceptable level of clinical benefit.
  - or*
  - Patients in whom standard therapies are contraindicated.

OR

- Pediatric post renal transplantation patients with nephrotic syndrome associated with primary FSGS.

## 1.5 WARNINGS

1. **Before using the LIPOSORBER® LA-15 System, carefully review the “LIPOSORBER® LA-15 System Operator’s Manual for use in the treatment of pediatric patients with primary focal segmental glomerulosclerosis (FSGS)”.** Persons performing the procedures must be qualified to perform extracorporeal procedures, and have completed the required training program. Users should follow all operating or maintenance procedures published by Kaneka Pharma America LLC and use only those disposable device components recommended by Kaneka Pharma America LLC. To do otherwise may result in injury or loss of life.
2. This system may be used only as prescribed by a licensed and appropriately trained physician. While connected to the extracorporeal system, the patient must be attended to at all times by a physician or qualified health-care professional adequately trained in all aspects of the procedure.
3. **The storage and use of this disposable device other than in accordance with the instructions published by Kaneka Pharma America, LLC or the use of disposable device components not recommended by Kaneka Pharma America may result in patient injury or loss of life.** The manufacturer and distributor(s) of this device will not be responsible for patient safety if the procedures to operate and maintain the LIPOSORBER® LA-15 System are other than those specified in the package inserts and the Operator’s Manual for FSGS.
4. Do not apply whole blood directly to the LIPOSORBER® LA-15 LDL Adsorption Column. The column is designed for perfusion of plasma only.
5. Make sure that the plasma flows in the direction of the arrow on the label of the LIPOSORBER® LA-15 LDL Adsorption Columns.
6. **Rinsing and subsequent priming of the fluid pathway of the disposables with appropriate solutions are necessary before commencing the procedure.** Because air bubbles in the disposables may lead to complications such as coagulation of plasma and impairment of performance, give full attention to measures that will prevent air-bubble migration into the disposables during rinsing and priming.
7. While operating, the differential pressure across the LIPOSORBER® LA-15 Adsorption Column must be **under 100 mmHg, and the transmembrane pressure (TMP) of the SULFLUX® KP-05 Plasma Separator must be under 60 mmHg.** If either an extreme pressure drop across the column or an extreme TMP occurs, the blood flow rate and/or plasma separation rate should be lowered appropriately or even stopped if necessary.
8. **Citrate preparation (ACD) should never be used as an anticoagulant in the system. The LIPOSORBER® LA 15 System is designed solely for treatment using heparin as an anticoagulant.** Anticoagulation is required to prevent thrombus formation from occurring within the extracorporeal circuit. Anticoagulation with too much heparin is associated with an increased risk of bleeding for the patient, especially after the procedure. In order to reduce the risk of bleeding, the puncture sites should be sufficiently compressed so that bleeding is stopped. (See Operator’s Manual at Section 1.7 Adverse Events) **In some patients the potential for development of a coagulopathy extending several days post-therapy may exist.** In addition to adjusting heparin dosage based on clinical observation during and after the apheresis procedure, Activated Clotting Time and/or partial thromboplastin time (PTT) values may be used. (See Operator’s Manual at Section **1.8.2 Instructions for Use regarding “Determining Heparin Dosage”**)

9. No chemicals or solvents are to be used either inside or outside of the disposables.
10. The LIPOSORBER® LA-15 LDL Adsorption Columns are disposable and are **intended for use in a single procedure only. Never reuse.** Discard this disposable after each procedure.
11. Due to the risk of reduction of blood pressure with the Liposorber LA-15 device, extra caution should be exercised in use of the device in patients with systolic and/or diastolic blood pressure  $\leq$  5<sup>th</sup> percentile for age, gender and height.
12. Prior to initiating an LDL-apheresis procedure, carefully review the package inserts for all disposables and other materials to be used during the procedure. Failure to comply strictly with such package inserts, including the instructions for use, may result in serious injury to or possible death of patients.
13. Use special caution in patients where the extracorporeal volume of approximately 400 ml potentially will exceed 10% of the patient's total blood volume. Such patients are at higher risk of experiencing hypovolemia, which is sometimes followed by hypotension.
14. During an LDL-apheresis procedure, 0.9% Sodium Chloride Injection, USP, 5% Sodium Chloride Injection, USP, Lactated Ringer's Injection, USP, and Heparin Sodium Chloride Injection, USP, are used. Carefully identify each solution and ensure that it is properly connected to the LIPOSORBER® LA-15 System. **Using the incorrect solution may result in serious injury or possible death.**
15. **To minimize the risk of air embolism, the return tubing line must be connected to the air bubble detector.**
16. In case of a power failure or system shutdown, terminate the procedure immediately according to the instructions provided in Chapter 7.6 Manual Blood Return of the Operator's Manual for the LIPOSORBER® LA-15 System.

## 1.6 PRECAUTIONS

1. The need for the administration of angiotensin receptor blockers (ARBs) prior to the treatment on the day of the apheresis treatment should be determined by the treating physician. If the treating physician determines that it is not necessary, the patient should not take ARBs on the day of the apheresis treatment until the apheresis treatment is completed in order to minimize the risk of a hypotensive reaction during the extracorporeal therapy.
2. The safety and probable benefit of LDL-apheresis using the LIPOSORBER® LA-15 System has not been established for pregnant women or for women during the lactation period, e.g. the effect of treatments on folic acid levels has not been determined.
3. The safety and probable benefit of LDL-apheresis using the LIPOSORBER® LA-15 System have not been established for: (1) patients less than 21 kg in body weight; (2) patients less than 5 years of age; (3) patients with certain cardiac impairments such as uncontrolled arrhythmia, unstable angina, decompensated congestive heart failure or valvular disease; and (4) patients with thyroid disease or liver abnormalities.
4. The SULFLUX® KP-05 Plasma Separator, LIPOSORBER® LA-15 Adsorption Column set, and the Blood Tubing System for Apheresis (NK-M3R(U)) are disposable and are **intended for use in a single procedure only. Never reuse.** Discard all used and unused disposables after each procedure.
5. Physicians and operators should follow the OSHA and the CDC/ACIP Adult Immunization Guidelines for Hemodialysis Patients. It is recommended that patients be screened for Hepatitis B and other infectious diseases; however, due to possible exposure to hepatitis virus, human immunodeficiency virus, and other infectious agents when handling extracorporeal blood circuits, blood or blood products, universal precautions should be taken at all times to prevent the exposure to and transmission of such agents.
6. When disposing of the disposable device components and wastes, comply with all local requirements and the policy of the facility regarding precautions for and prevention of infection and environmental pollution.
7. Medical personnel should monitor the patient for adverse symptoms at all times during treatment and should be trained as to the protocol for responding with appropriate interventions. (See Operator's Manual at Section **1.7 Adverse Events**)
8. Closely monitor patient clotting time periodically during the procedure to ensure that an adequate level of anticoagulation is maintained.
9. Instructions for heparin administration should be followed as stated in the guidance provided by the manufacturer in the Operator's Manual. The amounts of heparin outlined in the Operator's Manual are intended as general suggestions. **The exact amount, frequency and method of administration of heparin are the sole responsibility of the prescribing/attending physician and should be selected based on the individual patient's clinical condition.**
10. All connections of the extracorporeal circuit should be checked carefully prior to initiating and during the procedure. Avoid unnecessary kinking of the tubing lines and the patient's vascular access devices at all times.



11. The transducer protectors must be attached and locked to the machine and tubing lines. Strict aseptic technique should be used during this and all procedures. After the completion of the procedure, properly dispose of all used and unused transducer protectors. **Do not reuse.**
12. Drip chambers in the extracorporeal circuit should be kept at least 2/3 to 3/4 full and monitored at all times in order to decrease the risk of air embolism.
13. Each tubing line must be properly connected and cleared of air, prior to the start of Rinse. Do not allow air to be trapped in the set. Puncturing tubing lines may cause air embolism.
14. The fluid circuit of this system is intended to be sterile and nonpyrogenic. Aseptic handling techniques are necessary to maintain these conditions. Check the packaging for the disposable device components to ensure that it is intact. Do not use a disposable product if the package, sterile bag, protective cap or the product itself is damaged. Do not open the sterile bags containing the disposables until use.
15. The LIPOSORBER® LA-15 System includes a blood warmer with a temperature setting range of 35-40 °C. It is recommended that the blood warmer be set at a temperature between 36-38 °C in order to avoid significant decreases in blood temperature during extracorporeal circulation.
16. In transporting and storing the device components, handle with care and store all disposables in a clean and secure area at room temperature (5-30 °C), avoiding exposure to direct sunlight, high humidity or excessive vibration. **Handle the disposables with care to avoid dropping or other sudden impacts and never allow them to freeze. Do not use components which may have been damaged or frozen.**
17. Anemia may be minimized by the appropriate use of iron supplements.

## 1.7 ADVERSE EVENTS

Adverse events that may be associated with the use of the device include, but are not limited to, those listed in the following paragraphs. If a patient experiences an adverse reaction during a procedure, the physician should stop the procedure until the cause of the reaction has been determined and the patient's condition stabilized. The physician should determine all medical responses to adverse reactions based upon the individual patient's physical condition.

- 1) Death
- 2) Cardiac: Various abnormal heart rhythms may develop including bradycardia, tachycardia, and other arrhythmias. Myocardial infarction is another potential adverse cardiac event. If these are detected by vital sign monitoring, physical examination, or electrocardiography, immediate assessment and continued monitoring is essential.
- 3) Thrombocytopenia
- 4) Infection/bacteremia: Use of the device requires a central venous access (catheter). Infection of the catheter may occur due to exit site infection, improper use of the catheter, or internal catheter infection. Aseptic technique is required for catheter use. If an infection or bacteremia is suspected, culture of the catheter ports, in conjunction with peripheral culture (optional), is required. Antibiotic therapy should be provided according to physician discretion.
- 5) Hypersensitivity (anaphylactoid) reaction: Use of angiotensin-converting enzyme inhibitors (ACEi) within 24 hours of therapy with the device can cause an increase in bradykinin levels, resulting in severe hypotension. ACEi should not be taken within 24 hours of therapy with the device.
- 6) Nausea and Vomiting. The procedure should be stopped and the etiology of the nausea and vomiting investigated (e.g., hypotension).
- 7) Reduction in Vitamin E level
- 8) Transient decrease in serum protein and albumin level
- 9) Hypotension: The procedure should be stopped, and the patient should be placed in the Trendelenburg position and/or receive a fluid challenge. If the hypotension persists, the procedure should be terminated. Note: For an "anaphylactoid"- like reaction, administration of epinephrine, sympathomimetic drugs, prednisolone, anti-histamines, and/or calcium have been reported by clinicians as effective interventions.
- 10) Abdominal symptoms. Patients may exhibit nausea, vomiting abdominal discomfort. These events should be addressed with conservative management and supportive care. The procedure should be stopped and the etiology of the nausea and vomiting investigated (e.g., hypotension).
- 11) Flushing/blotching: Check vital signs and reduce the blood flow rate. If symptoms are persistent or repetitive, consider the administration of diphenhydramine (e.g., Benadryl).
- 12) Angina/chest pain: The procedure should be stopped and medical therapy instituted at the discretion of the physician. If the angina persists, the procedure should be terminated.

- 13) Fainting/lightheadedness: See hypotension.
- 14) Anemia: May be minimized by the appropriate use of iron supplements.
- 15) Prolonged bleeding (at cannulation site after removing venous cannulae): Direct manual pressure should be applied until the bleeding stops. If prolonged bleeding occurs (in excess of 20 minutes), adjustment of the heparin dosing may be necessary. It is recommended that, during the subsequent procedure, the heparin dose be reduced and monitored by Activated Clotting Time (ACT). Repetitive LDL apheresis treatment may affect the patient's clotting time. Therefore, a periodic check (e.g., every 3 months), of other relevant coagulation parameters is recommended, including the number of thrombocytes and the fibrinogen concentration, in order to ensure that these parameters are sufficient to maintain adequate coagulation.
- 16) Hemolysis: as evidenced by discoloration of plasma or hemolysis as Indicated by activation of the blood leak detector alarm of the MA-03. If either indicator of hemolysis occurs, the procedure should be terminated and the patient's hematocrit, urine output and kidney function monitored.
- 17) Device malfunction: The system contains various components, including LDL apheresis columns (2), plasma separator, tubing system, and an electronic control unit. System malfunction may occur due to any of these components. If system malfunction occurs, the patient's vital signs and clinical status should be monitored immediately and repeatedly. It may be necessary to suspend treatment if the patient develops symptoms or if the problem cannot be readily solved.
- 18) Vertigo
- 19) Diaphoresis
- 20) Urticaria: Mild discomfort may occur requiring supportive care. Vital signs and physical examination of the patient are required in order to assess if urticaria is a component of a more severe, generalized reaction to the therapy. Specific associated symptoms, including, but not limited to, difficulty breathing, chest pain, and dizziness should be addressed by the physician.
- 21) Shivering
- 22) Headaches

## 1.8 Clinical Data

Clinical data to support the safety and probable benefit of LIPOSORBER® LA-15 System for FSGS can be divided to pre-transplant FSGS and post-transplant FSGS.

### Pre-transplant FSGS

For the pre-transplant (FSGS) population, Hattori et al (2003) describes the outcomes of eleven (11) children with steroid resistant primary FSGS who were treated unsuccessfully with conventional-dose cyclosporine therapy and showed persistent nephrotic range proteinuria. At the time of treatment with the Liposorber LA-15 System, none of the patients had received a renal transplant (“pre-transplant”). At the start of the 7<sup>th</sup> apheresis treatment (average number of treatments: 11.5), prednisone was administered at a dose of 1mg/kg/d for 6 weeks, followed by a tapering schedule during subsequent months.

The effectiveness endpoint was the number of patients achieving remission of nephrotic syndrome. Other measures included renal function (i.e., glomerular filtration rate (GFR)), degree of proteinuria, cholesterol level and complications of therapy.

The criteria used to assess clinical response were:

- Remission of nephrotic syndrome (NS)
  - Complete remission: reduction in urinary protein (< 4 mg/m<sup>2</sup>/h) for 3 consecutive days with normal serum albumin and cholesterol levels, and stable renal function
  - Partial remission: lower urinary protein levels but persistent non-nephrotic proteinuria (protein < 40 mg/m<sup>2</sup>/h) with normal serum albumin
- Renal Function (as GFR, in ml/min/1.73m<sup>2</sup>)
- Proteinuria (g/m<sup>2</sup>/day).

### Results

#### Effectiveness:

- Achievement of remission (defined above) of nephrotic syndrome was observed in 7/11 patients (5 complete and 2 partial).
- Renal function (GFR) for the five (5) patients who achieved complete remission was normal during follow-up (median: 4.4 years, range: 4.0-11.1 years).
- Proteinuria declined in 7/11 patients (as evidenced by remission of nephrotic range proteinuria).

#### Safety:

Only one patient developed a complication (infection of the indwelling catheter used to receive the therapy).

### Conclusion

The authors suggest that combined LDL-apheresis and prednisone therapy can be a valuable therapeutic option for treating patients with steroid resistant FSGS.

### Post-transplant FSGS

For the post-transplant FSGS population, Muso et al (2007) describes 41 patients with refractory FSGS. The study population included a sub-set of 7 patients who developed recurrent FSGS after undergoing renal transplantation. The study was intended to evaluate the long-term outcome of LDL apheresis in patients with FSGS.

The study included the change in lab values (e.g., serum protein, serum albumin, proteinuria)

at 1 month after treatment and measured the number of patients achieving remission of nephrotic syndrome at 2 and 5 years after Liposorber treatment. Although the investigators did not indicate that any of the patients included in the analysis were children, the results can be used to assess effectiveness in children as the course of the disease is sufficiently similar in both adults and children.

The criteria used to assess clinical response were:

- Remission of nephrotic syndrome (NS)
  - Complete remission
  - Type I incomplete remission: proteinuria negative or < 1.0 g/day and serum albumin > 3.0 g/dL
  - Type II incomplete remission: proteinuria < 3.5 g/day but serum albumin < 3.0 g/dL

### *Results*

- At 1 month after LDL apheresis total serum protein and albumin increased significantly and proteinuria was significantly decreased.
- Remission of nephrotic syndrome was observed in 18/29 patients followed at 2 years (62%).
- Remission of nephrotic syndrome was observed in 13/15 patients followed at 5 years (86%).

The seven post-transplant patients were included in the 41 patients analyzed at 1 month. The authors did not analyze the data collected from pre- and post-transplant patients separately. Instead, the authors state that the exclusion of the post-transplant patient data did not impact the data trend or significance of the results, indicating that the post-transplant data were similar as a group to the pre-transplant patients in terms of increase in serum protein and albumin and decrease in proteinuria. The authors did not indicate the number of post-transplant patients included in the 2 and 5 year follow-up.

### *Safety*

The incidence of adverse events was not reported.

### *Conclusion*

The authors conclude that early administration of LDL-apheresis after the onset of nephrotic syndrome associated with FSGS provides a good long-term outcome.

### *References*

1. Hattori M, et al: A Combined Low-Density Lipoprotein Apheresis and Prednisone Therapy for Steroid-Resistant Primary Focal Segmental Glomerulosclerosis in Children. *Amer J Kidney Dis* 42:1121-1130, 2003.
2. Muso E, et al: Beneficial effect of low-density lipoprotein apheresis (LDL-A) on refractory nephrotic syndrome (NS) due to focal glomerulosclerosis (FGS). *Clin Nephrol.* 67(6):341-4, 2007.

## 1.9 INSTRUCTIONS FOR USE

Use of the LIPOSORBER® LA-15 System in pediatric patients with FSGS is recommended to occur twice weekly for 3 weeks followed by once per week for six weeks.

### 1.9.1 Determining Plasma Volume to be Treated

The clinical experiences in Japan suggest that treating 60 mL/kg patient plasma volumes during a single procedure is acceptable for pediatric patients with primary focal segmental glomerulosclerosis. The plasma volume to be treated can be calculated as follows:

- STEP 1: Obtain patient weight (kilograms)
- STEP 2: Multiply the patient weight by 60.
- STEP 3: Round up the value from Step 2 to the nearest hundredth.  
This is the plasma volume to be treated.

#### **Example:**

- STEP 1: Obtain patient weight.  
Weight: 48kg
- STEP 2: Multiply value from STEP 1 by 60 → **48 x 60 = 2,880**
- STEP 3: Round up value from STEP 2 to the nearest hundredth → **2,900 ml**  
This is the plasma volume to be treated.

The amount of plasma treated will require adjustment as clinically indicated by the physician in order to achieve and optimize individualized patient treatment goals.

### 1.9.2 Determining Heparin Dosage

Although heparin administration procedures vary and are adjusted to the requirements of the individual patient by a supervising physician, a proper heparinization schedule **must be** initiated before and maintained throughout LDL-apheresis to prevent clotting and subsequent blood path obstruction. The following are examples of heparinization schedules.

1. Priming Solution. Lactated Ringer's Injection, USP (1,000 ml) should contain 2,000-3,000 USP units of heparin.
2. Loading Dose (Manual Infusion). Obtain PTT and PT pretreatment levels prior to initiation of LDL-apheresis therapy. If values are in the normal range, the recommended loading dose is approximately 25 USP units of heparin per kilogram of body weight. If a patient's PTT or PT is abnormally high, the physician should consider a lower loading dose of heparin.

## 1. INTRODUCTION

3. Continuous Heparinization. Continuous heparinization is required during the LDL-apheresis procedure. Based upon a normal PTT and PT, approximately 25 USP units of heparin per kilogram of body weight per hour is recommended. During the first few apheresis treatments, coagulation test results should be monitored frequently to establish a coagulation profile for the individual patient. A monitoring schedule for these initial treatments should consist of a pre-heparinization PTT, PT, and activated clotting time (ACT) measurement. The ACT measurements should be performed at 30-minute intervals during the treatment. ACT levels should be maintained within a range of 180-250 seconds or 1.5 to 3 times the normal range. Once a patient's heparin regimen has been established, a patient's ACT may be followed less frequently during subsequent treatments.

A heparin pump is used to deliver heparin into the blood withdrawal line at a rate necessary to maintain a desired clotting time. A heparin pump infusion rate between 1,000-3,000 USP units of heparin per hour usually is sufficient.

Detailed Instructions for Use are set forth in the accompanying Operator's Manual for the LIPOSORBER<sup>®</sup> LA-15 System and in the package inserts for the LIPOSORBER<sup>®</sup> LA-15 Adsorption Column, SULFLUX<sup>®</sup> KP-05 Plasma Separator, and Tubing System for Plasmapheresis (NK-M3R(U)). **The procedures outlined in the Operator's Manual must be followed exactly as specified. No adjustments or modifications of such procedures not specifically stated in the Operator's Manual may be made. In the event of equipment or device failure or malfunction, discontinue the procedure and follow the instructions in the Operator's Manual.**

## 1.10 Moving and Transportation of the MA-03

### CAUTION

When moving the MA-03, do not put your feet close to the casters. They may get crushed.

### 1.10.1 Moving of the MA-03 Indoors

#### ■ Normal Moving

1. Release the lock of casters.
2. After that, the MA-03 can be moved or turned freely.

### CAUTION

If moving the MA-03 down or up a slope (an angle over 10°), two people should be used.

### CAUTION

When you move MA-03, please move the external lamp to the lowest position. And be careful not to hit the ceiling and the upper frame of the door.

#### ■ Moving Over Different Floor Levels (i.e. Entrance of an elevator)

1. To prevent damage or falling of the machine, always move the machine slowly while rolling over different floor levels or small bumps.

### CAUTION

To prevent tip over, do not incline the MA-03.

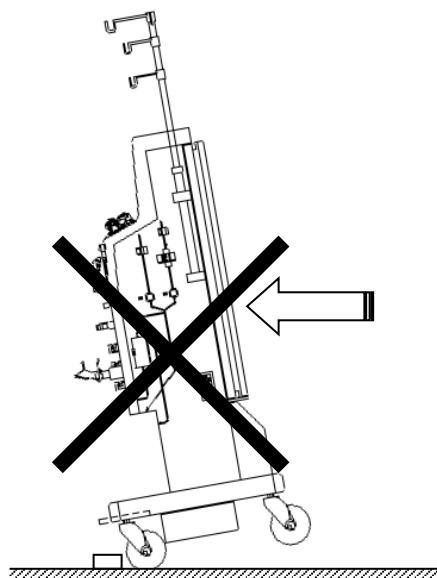



 **CAUTION**

Do not lift the machine by grasping the external lamp or bag hanger.  
This can damage the machine.

### 1.10.2 Transportation of the MA-03 Outdoors

1. The machine must not be moved across uneven surfaces (i.e., stone paved roads and the like).
2. If the machine needs to be moved across an uneven surface, protect it from vibration by placing the machine on a sturdy handcart with proper padding.
3. Before transporting the machine, remove all equipments and disposables such as solution bags, the external lamp and bag hangers.
4. "Power Failure" buzzer sounds if POWER ON Button was accidentally pressed while transporting the machine.

 **NOTICE**

"Power Failure" buzzer stops when POWER OFF Button on the Operation Panel is pressed for more than 3 sec.

## 1.11 EMC information

The MA-03 conforms to the EMC standard of IEC60601-1-2:2001

### 1.11.1 Electromagnetic Emission and Electromagnetic Immunity

The MA-03 is intended for use in the electromagnetic environment specified below. The customer or the user of the MA-03 should assure that it is used in such an environment.

Emissions test	Compliance	Electromagnetic environment - guidance
RF emissions CISPR 11	Group 1	The MA-03 uses RF energy only for its internal function. Therefore, its RF emissions are very low and are not likely to cause any interference in nearby electronic equipment.
RF emissions CISPR 11	Class A	The MA-03 is suitable for use in all establishments other than domestic and those directly connected to the public low-voltage power supply network that supplies buildings used for domestic purposes.
Harmonic emissions IEC 61000-3-2	Class A	
Voltage fluctuations / flicker emissions IEC 61000-3-3	Complies	

# 1. INTRODUCTION

Guidance – electromagnetic immunity			
Immunity test	IEC60601 test level	Compliance level	Electromagnetic environment - guidance
Guidance – electromagnetic immunity			
Immunity test	IEC60601 test level	Compliance level	Electromagnetic environment - guidance
Electrostatic discharge (ESD) IEC 61000-4-2	±6kV contact ±8kV Air	±6kV contact ±8kV Air	Floors should be wood, concrete or ceramic tile. If floors are covered with aynthetic material, the relative humidity should be at least 30 %.
Electrical fast transient / burst IEC 61000-4-4	±2kV for Power supply line ±1kV for input / output line	±2kV for Power supply line ±1kV for input / output line	Mains power quality should be that of a typical commercial or hospital environment.
Surge IEC 61000-4-5	±1kV differential mode ±2kV common mode	±1kV differential mode ±2kV common mode	Mains power quality should be that of a typical commercial or hospital environment.
Voltage dips, short interruptions and voltage variations on power supply input lines IEC 61000-4-11	<5% $Ut$ (>95% dip in $Ut$ ) for 0.5 cycle  40% $Ut$ (60% dip in $Ut$ ) for 5 cycle  70% $Ut$ (30% dip in $Ut$ ) for 25 cycle  <5% $Ut$ (>95% dip in $Ut$ ) for 5 s	5% $Ut$ (>95% dip in $Ut$ ) for 0.5 cycle  40% $Ut$ (60% dip in $Ut$ ) for 5 cycle  70% $Ut$ (30% dip in $Ut$ ) for 25 cycle  <5% $Ut$ (>95% dip in $Ut$ ) for 5 s	Mains power quality should be that of a typical commercial or hospital environment. If the user of the MA-03 requires continued operation during power mains interruptions, it is recommended that the MA-03 be powered from an uninterruptible power supply or a battery.
Power frequency (50/60Hz) magnetic field  IEC61000-4-8	3A/m	3A/m	Power frequency magnetic field should be measured in the intended installation location to assure that it is sufficiently low.
NOTE $Ut$ is the a.c. mains voltage prior to application of the test level.			

<p>Conducted RF IEC61000-4-6</p>	<p>3Vrms (150kHz to 80MHz)</p>	<p>3Vrms</p>	<p>Potable and mobile RF communications equipment should be used no closer to any part of the MA-03 including cables, than the recommended separation to the frequency of the transmitter.</p> <p><b>Recommended separation distance</b> <math>d=1.2\sqrt{P}</math></p>
<p>Radiated RF IEC61000-4-3</p>	<p>3V/m (80MHz to 2.5GHz)</p>	<p>3V/m</p>	<p><math>d=1.2\sqrt{P}</math> (80MHz to 800MHz) <math>d=2.3\sqrt{P}</math> (800MHz to 2.5GHz)</p> <p>where <math>P</math> is the maximum output power rating of the transmitter in watts (W) according to the transmitter manufacture and <math>d</math> is the recommended separation distance in meters (m) (<math>\sqrt{P}</math> is a square root of P.)</p> <p>Field strengths from fixed RF transmitters, as determined by an electromagnetic site survey,"a" should be less than the compliance level in each frequency range."b"</p> <p>Interference may occur in the vicinity equipment maked with the following symbol:</p> 
<p>NOTE 1 At 80MHz and 800MHz, the higher frequency range applies. NOTE 2 These guidelines may not apply in all situations. Electromagnetic propagation is affected by absorption and reflection from structures, objects and people.</p>			
<p>"a" Field strengths from fixed transmitters, such as base stations for radio (cellular / cordless) telephones and land mobile ratios, amateur radio, AM and FM radio broadcast and TV broadcast cannot be predicted theoretically with accuracy. To assess the electromagnetic environment due to fixed RF transmitters, an electromagnetic site survey should be considered. If the measured filed strength in the location in which the MA-03 is used exceeds the applicable RF compliance level above, the MA-03 should be observed to verify normal operation. If abnormal performance is observed, additional measures may be necessary, such as re-orienting or relocating the MA-03. "b" Over the frequency range 150kHz to 80MHz, it is preferable that the field strengths should be less than 3 V/m.</p>			

### 1.11.2 Recommended separation distances between portable and mobile RF communications equipment and the MA-03

The MA-03 is intended for use in an electromagnetic environment in which radiated RF disturbances are controlled. The customer or the user of the MA-03 can help prevent electromagnetic interference by maintaining a minimum distance between portable and mobile RF communications equipment (transmitters) and the MA-03 as recommended below, according to the maximum output power of the communications equipment.

Rated maximum output power of transmitter W	Separation distance according to frequency of transmitter m		
	150kHz to 80MHz $d=1.2\sqrt{P}$	80MHz to 800MHz $d=1.2\sqrt{P}$	800MHz to 2.5GHz $d=2.3\sqrt{P}$
0.01	0.12	0.12	0.23
0.1	0.38	0.38	0.73
1	1.2	1.2	2.3
10	3.8	3.8	7.3
100	12	12	23

For transmitters rated at a maximum output power listed above, the recommended separation distance  $d$  in meters (m) can be estimated using the equation applicable to the frequency of the transmitter, where  $P$  is the maximum output power rating of the transmitter in watts (W) according to the transmitter manufacturer.

NOTE 1 At 80MHz and 800MHz, the separation distance for higher frequency range applies.

NOTE 2 These guidelines may no apply in all situations. Electromagnetic propagation is affected by absorption and reflection from structures, objects and people.

## 1.12 THE MA-03 DANGER, WARNING AND CAUTION

### DANGER

Do not use the machine where highly flammable anesthetic or flammable gas is used, in a high pressure oxygen room or in oxygen tent.  
This could trigger an explosion.

### WARNING

Use of Machine by an unqualified operator may result in injury or death to the patient and the operator, or damage to the MA-03.

### WARNING

Grounding reliability can only be achieved when the machine is connected to an equivalent receptacle marked "Hospital only" or "Hospital grade".  
Never use any adaptor which breaks the contact between the machine ground and the receptacle ground.  
When not grounded, this could cause electric shock.

### WARNING

In the machine's vicinity, never use devices that cause electromagnetic interference, such as mobile phones, CB wireless transmitters, electric cauteries or defibrillators while the machine is in operation. The machine may malfunction.

### WARNING

If any device which transmits electromagnetic wave is used around the MA-03, this may cause the MA-03 to malfunction.  
Please follow instructions indicated in section 1.10 of this manual.

### WARNING

Use only authorized accessories for the machine.  
If an improper accessory is connected to the MA-03, physical injury may result.

### WARNING

The machine can not be used if a defibrillator needs to be used on the patient.  
Do not touch the machine when discharging the defibrillator.  
Confirm proper operation of the machine after defibrillator use. Use of a defibrillator could negatively affect the machine's safe operation.

 **WARNING**

Only use specified power supply voltage otherwise fire or electric shock may occur.

 **WARNING**

Do not open access covers of the MA-03.  
This could cause fire or electric shock.

 **WARNING**

Do not place heavy apparatus on the power cord.  
This could cause fire or electric shock.

 **WARNING**

A new, sterile transducer protective filters should be attached to all pressure ports.  
This will prevent cross infection to patients through the machine.  
If the transducer protective filters are wet and air is not able to pass, replace the transducer protective filter with a new one and clear the monitor line.

 **WARNING**

If the external transducer protective filter, internal transducer protective filter and the internal transducer are contaminated with blood replace the filter with a new one and sterilize or replace the transducer and the associated parts.  
Only authorized KANEKA PHARMA AMERICA LLC service personnel should perform any parts replacement or sterilization.

 **WARNING**

Pressure changes resulting from line separation or needle removal may be too subtle for the system to detect.  
All connections must be properly secured and visually confirmed regularly.  
Access sites and connections should remain uncovered for monitoring.

** WARNING**

Instructions for operation:

1. The operator must confirm and verify that the indicated value is equal to the entered value every time the operator sets a parameter.
2. If the indicated value is not equal to the entered value, treatment must not be started in any case.

** WARNING**

Make sure fluid is not poured or splashed on the machine.

** WARNING**

Maintenance:

Only authorized KANEKA PHARMA AMERICA LLC service personnel should perform assembly, installation, adjustment, or repair of the machine.

** CAUTION**

The machine should be installed in the following locations:

1. Level and stable location.
2. A location with three (3) feet of space around the machine to let air circulate.
3. Ambient temperature should be between 50-95 degrees Fahrenheit and the humidity should be less than 85%.
4. A location for properly grounding the machine.

** CAUTION**

The machine should not be installed in the following locations:

1. A location where the machine is exposed directly to the sunlight for a long time. Especially, the LCD in the machine will be deteriorated by the ultraviolet ray of the sunlight. Therefore, do not leave the machine under direct sunlight for a long time.
2. A location where the machine is affected by splashed water or steam.
3. A location affected by vibrations and shocks.
4. A location where there is flammable or corrosive gases and fire.
5. A location where chemicals are stored.



## 1. INTRODUCTION

### CAUTION

If there is dew condensation on the machine, dry it well before turning the electric power on. Electric shocks could occur.

### CAUTION

While in use, constantly monitor the machine for safe and proper usage.

### CAUTION

Do not use ballpoint pens or other sharp-pointed objects to push the switches (buttons and keys). This may damage the front panel.

### CAUTION

Be sure to handle electric plugs properly, or electric shocks and fire may occur:

1. Never handle electric plugs with wet hands.
2. When pulling electric plugs, do not pull the cord.
3. If the machine will not be used for a long time, unplug the power cord.

### CAUTION

When cleaning the machine, do not use solvents like thinner and benzene and the like. The machine's surface may become damaged.

### CAUTION

Set the bag hangers lower than six (6) feet of height to minimize the risk of the machine tilting over.

**⚠ CAUTION**

Measure for LCD's abnormality

If the LCD screen does not display any contents or a key has no response, turn off the machine immediately and then perform blood return by using the manual pump handle.

(Please refer to Chapter 7.6 Manual Blood Return of the operator's manual )

[Operating keys in abnormal state of the LCD screen may lead to an unintended action of the machine.]

**⚠ CAUTION**

Do not leave the machine near the ultraviolet-rays sterilization light for a long time.

[Ultraviolet-rays causes a deterioration or discoloration of the plastic parts on the outer surface and the LCD, and that causes a malfunction of the machine.]

## Side Panel Caution Label

A caution label is located at the position shown in Figure 1.1.  
Before operating the MA-03, read the label.

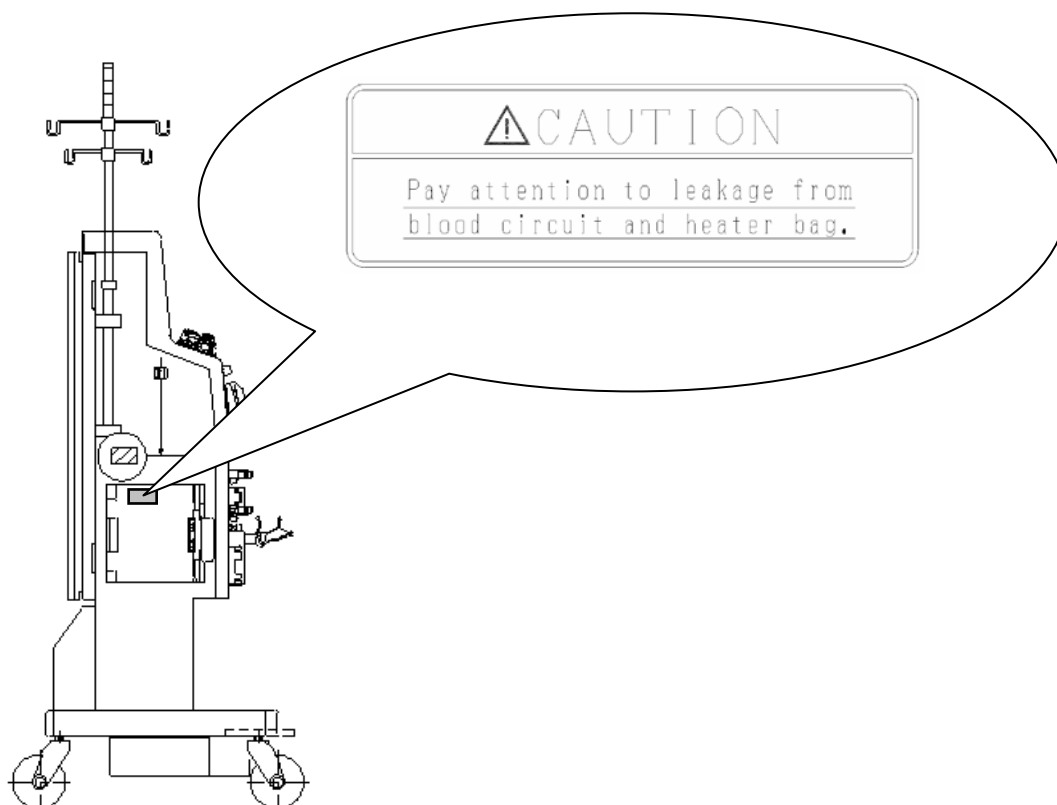

Figure 1.1 Caution Label

## 1.13 LIMITS TO THE MANUFACTURER'S RESPONSIBILITY

- The LIPOSORBER<sup>®</sup> LA-15 System must be used in accordance with this Operator's Manual. **The use of operating or maintenance procedures other than those published by Kaneka Pharma America LLC or the use of disposable device components not recommended by Kaneka Pharma America LLC may result in injury or loss of life.** Kaneka Pharma America LLC, the manufacturers of the MA-03 or the disposable device components, or any distributor of the LIPOSORBER<sup>®</sup> LA-15 System will not be responsible for resulting injury or damage if the procedures to operate and maintain the LIPOSORBER<sup>®</sup> LA-15 System are other than those specified by Kaneka Pharma America LLC in the Operator's Manual. Persons performing the procedures must be appropriately trained and qualified.
- In no event shall Kaneka Pharma America LLC or the manufacturers of the MA-03 or of the disposable device components or any distributor of the LIPOSORBER<sup>®</sup> LA-15 System be liable for any losses or damages caused or resulting from any negligence in the selection of patients outside the indicated population, operation of the LIPOSORBER<sup>®</sup> LA-15 System, or treatment of patients with the LIPOSORBER<sup>®</sup> LA-15 System by any third party.
- Except as expressly set forth herein, Kaneka Pharma America LLC makes no warranty whatsoever, express or implied, and **specifically disclaims any warranty of merchantability or fitness for a particular purpose** as to the LIPOSORBER<sup>®</sup> LA-15 System.
- **In no event shall Kaneka Pharma America LLC, the manufacturers of the MA-03 or of the disposable device components or any distributor of the LIPOSORBER<sup>®</sup> LA-15 System be liable for any special, consequential or incidental losses or damages for any reason.**
- Certain solutions and disposable products available from other manufacturers are used with the LIPOSORBER<sup>®</sup> LA-15 System. Kaneka Pharma America LLC has no control over variability, tolerances, mechanical strength or changes in these products which may exist from time to time. Therefore, Kaneka Pharma America LLC cannot ensure that the disposable products of other manufacturers will function in a satisfactory manner and expressly disclaims any responsibility or liability for any injury, harm, damages or loss resulting from the use or malfunction of such products.