

# Guidance for Industry and FDA Staff

---

## Hospital Bed System Dimensional and Assessment Guidance to Reduce Entrapment

**Document issued on: March 10, 2006**

**The draft of this document was issued on August 30, 2004.**

For questions regarding this document contact Jay A. Rachlin, Office of Communication, Education, and Radiation Programs, 301-796-5722, [jay.rachlin@fda.hhs.gov](mailto:jay.rachlin@fda.hhs.gov) or Joan Ferlo Todd, Office of Surveillance and Biometrics, 301-796-6079, [joan.todd@fda.hhs.gov](mailto:joan.todd@fda.hhs.gov).



**U.S. Department of Health and Human Services  
Food and Drug Administration  
Center for Devices and Radiological Health**

**Division of Device User Programs and Systems Analysis (HFZ-230)  
Office of Communication, Education, and Radiation Programs**

**Division of Postmarket Surveillance (HFZ-520)  
Office of Surveillance and Biometrics**

# **Preface**

## **Public Comment**

Written comments and suggestions may be submitted at any time for Agency consideration to the Division of Dockets Management, Food and Drug Administration, 5630 Fishers Lane, Room 1061, (HFA-305), Rockville, MD, 20852. Alternatively, electronic comments may be submitted to <http://www.fda.gov/dockets/ecomments>. When submitting comments, please refer to Docket No. 2004D-0343. Comments may not be acted upon by the Agency until the document is next revised or updated.

## **Additional Copies**

Additional copies are available from the Internet at <http://www.fda.gov/cdrh/beds>, or you may either send a fax request to 301-847-8149 to receive a hard copy of the document, or send an e-mail request to [DSMICA@CDRH.FDA.GOV](mailto:DSMICA@CDRH.FDA.GOV) to request hard or electronic copy. Please use the document number 1537 to identify the guidance you are requesting.

# Table of Contents

<b>Introduction .....</b>	<b>1</b>
<b>The Least Burdensome Approach.....</b>	<b>2</b>
<b>Background.....</b>	<b>2</b>
Standards and Future Harmonization.....	4
<b>Organization of this Guidance.....</b>	<b>5</b>
<b>Scope.....</b>	<b>5</b>
Articulation.....	7
Legacy Beds .....	7
Exclusions.....	8
<b>Reporting an Entrapment Adverse Event.....</b>	<b>9</b>
<b>Key Body Parts at Risk .....</b>	<b>10</b>
Head.....	10
Neck.....	11
Chest.....	12
<b>Potential Zones of Entrapment .....</b>	<b>13</b>
<b>A Retrospective Study of Entrapment Reports to FDA .....</b>	<b>14</b>
<b>Dimensional Limits for Identified Entrapment Zones 1-4.....</b>	<b>15</b>
Zone 1 – Within the Rail .....	15
Zone 2 – Under the Rail, Between the Rail Supports or Next to a Single Rail Support .....	16
Zone 3 – Between the Rail and the Mattress .....	17
Zone 4 – Under the Rail at the Ends of the Rail .....	18
Zone 5 – Between Split Bed Rails .....	19
Zone 6 – Between the End of the Rail and the Side Edge of the Head or Foot Board.....	19
Zone 7 – Between the Head or Foot Board and the End of the Mattress.....	20
<b>APPENDIX A: List of Hospital Bed Safety Workgroup (HBSW) Participating Organizations .....</b>	<b>22</b>
<b>APPENDIX B: Additional Information and Kit Information.....</b>	<b>23</b>
<b>APPENDIX C: References for National and International Entrapment Standards .....</b>	<b>24</b>
<b>APPENDIX D: Anthropometric References .....</b>	<b>25</b>
<b>APPENDIX E: Drawings of Potential Entrapment in Hospital Beds .....</b>	<b>27</b>
<b>APPENDIX F: HBSW Dimensional Test Methods for Bed Systems .....</b>	<b>28</b>

# Guidance for Industry and FDA Staff

---

## Hospital Bed System Dimensional and Assessment Guidance to Reduce Entrapment

*This guidance represents the Food and Drug Administration's (FDA's) current thinking on this topic. It does not create or confer any rights for or on any person and does not operate to bind FDA or the public. You can use an alternative approach if the approach satisfies the requirements of the applicable statutes and regulations. If you want to discuss an alternative approach, contact the FDA staff responsible for implementing this guidance. If you cannot identify the appropriate FDA staff, call the appropriate number listed on the title page of this guidance.*

### Introduction

This guidance provides recommendations relating to hospital beds<sup>1</sup> and hospital bed accessories. The guidance provides recommendations intended to reduce life-threatening entrapments associated with hospital bed systems.<sup>2</sup> It characterizes the body parts at risk for entrapment, identifies the locations of hospital bed openings that are potential entrapment areas, and recommends dimensional criteria for these devices.

Manufacturers may use this guidance when designing new beds to help ensure compliance with applicable FDA regulations such as the Quality System regulation<sup>3</sup>, to provide adequate labeling and instructions for use, and to assist in ensuring that their devices are safe when used as labeled. FDA encourages manufacturers to provide information to medical device

---

<sup>1</sup> The terms “medical bed” and “hospital bed” are used interchangeably throughout this document and include adult medical beds with siderails. See discussion in Scope, page 5.

<sup>2</sup> As used in this guidance, “hospital bed system” encompasses the bed frame and its components, including the mattress, bed side rails, head and foot board, and any accessories added to the bed.

<sup>3</sup> Title 21, Code of Federal Regulations, Part 820 – Quality System regulation.

## *Contains Nonbinding Recommendations*

distributors, clinicians, patients and families regarding mattress dimensions, compatible components, and issues of entrapment. In addition, the recommendations in this guidance may be useful in evaluating and reducing the entrapment risk presented by hospital beds that have been placed into use, also known as legacy beds.

Not all patients are at risk for an entrapment, and not all hospital beds pose a risk of entrapment. We suggest that facilities and manufacturers determine the level of risk for entrapment and take steps to mitigate the risk. Evaluating the dimensional limits of the gaps in hospital beds is one component of an overall assessment and mitigation strategy to reduce entrapment. As a result, healthcare facilities may use this guidance as part of a bed safety program to help identify entrapment risks that may exist with current hospital bed systems. Other educational documents are available to assist health care facilities in making decisions towards the goal of achieving a safe and comfortable sleeping environment for their patients.

FDA's guidance documents, including this guidance, do not establish legally enforceable responsibilities. Instead, guidances describe the Agency's current thinking on a topic and should be viewed only as recommendations, unless specific regulatory or statutory requirements are cited. The use of the word *should* in Agency guidances means that something is suggested or recommended, but not required.

## **The Least Burdensome Approach**

We believe we should consider the least burdensome approach in all areas of medical device regulation. This guidance reflects our careful review of the relevant scientific and legal requirements and what we believe is the least burdensome way for you to comply with those requirements. However, if you believe that an alternative approach would be less burdensome, please contact us so we can consider your point of view. You may send your written comments to the contact person listed in the preface to this guidance or to the CDRH Ombudsman. Comprehensive information on CDRH's Ombudsman, including ways to contact him, can be found on the Internet at <http://www.fda.gov/cdrh/ombudsman/>.

## **Background**

For 20 years, FDA has received reports<sup>4,5</sup> in which vulnerable patients<sup>6,7</sup> have become entrapped in hospital beds while undergoing care and treatment in health care facilities. The

---

<sup>4</sup> Ferlo Todd J, Ruhl C, Gross T P, "Injury and Death Associated with Hospital Bed Side Rails: Reports to the U.S. Food and Drug Administration from 1985 to 1995." American Journal of Public Health 1997; 87:1675-1677.

<sup>5</sup> Hospital Bed Safety Workgroup "A Guide to Bed Safety," <http://www.fda.gov/cdrh/beds/>.

<sup>6</sup> U. S. Food and Drug Administration. FDA Safety Alert: Entrapment Hazards with Hospital Bed Side Rails (August 23, 1995), U.S. Department of Health and Human Services.

## *Contains Nonbinding Recommendations*

term "entrapment" describes an event in which a patient/resident is caught, trapped, or entangled in the space in or about the bed rail<sup>8</sup>, mattress, or hospital bed frame. Patient entrapments may result in deaths and serious injuries.

FDA received approximately 691 entrapment reports over a period of 21 years from January 1, 1985, to January 1, 2006<sup>9</sup>. In these reports, 413 people died, 120 were injured, and 158 were near-miss events with no serious injury as a result of intervention. These entrapment events have occurred in openings within the bed rails, between the bed rails and mattresses, under bed rails, between split rails, and between the bed rails and head or foot boards. The population most vulnerable to entrapment are elderly patients and residents, especially those who are frail, confused, restless, or who have uncontrolled body movement. Entrapments have occurred in a variety of patient care settings, including hospitals, nursing homes, and private homes. Long-term care facilities reported the majority of the entrapments.

In response to continued reports of patient entrapment, the FDA, in partnership with the U.S. Department of Veterans Affairs, Health Canada's Medical Devices Bureau and representatives from national health care organizations and provider groups, patient advocacy groups, and medical bed and equipment manufacturers, formed a working group in 1999 known as the Hospital Bed Safety Workgroup (HBSW). Appendix A contains a list of HBSW participating organizations. The HBSW also worked in cooperation with the Joint Commission on Accreditation of Healthcare Organizations, the U.S. Centers for Medicare

---

<sup>7</sup> "Vulnerable patients" are defined in "A Guide to Bed Safety," developed by the Hospital Bed Safety Workgroup (described on pages 3-4), as: "Patients who have problems with memory, sleeping, incontinence, pain, uncontrolled body movement or who get out of bed and walk unsafely without assistance. These patients most often have been frail, elderly or confused."

<sup>8</sup> FDA uses the term "bed rails" frequently throughout this document. Commonly used synonymous terms are side rails, bed side rails, grab bars and safety rails. Bed rails are rigid bars that are attached to the bed and are available in a variety of sizes and configurations from full length to half, one-quarter, and one-eighth length and are used as restraints, reminders, or as assistive devices. An historical review can be found in Braun & Capezuti, "The Legal and Medial Aspects of Physical Restraints and Bed Side rails and Their Relationship to Falls and Fall-Related Injuries in Nursing Homes," DePaul Journal of Health Care Law, vol. 4, Fall 2000.

<sup>9</sup> FDA acknowledges several limitations of these adverse event report data. First, many adverse events may not be reported to the FDA, thus the true number of adverse events may be unknown. Second, the number of reported events does not represent incident rates for a given problem in the absence of a defined denominator—the number of individuals at risk for a given adverse event. Finally, many reports lack a complete and detailed description of the adverse event or are not verified. Despite these limitations, adverse event reports can suggest a profile of the areas or locations on a hospital bed that present a risk of entrapment, as well as the parts of the body that are at risk of entrapment.

## *Contains Nonbinding Recommendations*

and Medicaid Services, and the U.S. Consumer Product Safety Commission to improve patient safety associated with the use of hospital beds.

The HBSW identified 7 potential entrapment zones (See Potential Zones of Entrapment, Page 13) in hospital beds. The workgroup then developed (1) educational materials regarding entrapment associated with hospital beds, (2) clinical practice guidelines to reduce the occurrence of patient entrapment, (3) evidence-based dimensional guidelines for hospital beds, (4) test tools and methods to assess gaps in hospital bed systems, and (5) information to assist in mitigating entrapment risks in currently used hospital beds. See Appendix B for information on the availability of these materials.

Consistent with 21 CFR 10.115(f), the HBSW submitted to FDA recommendations for hospital bed dimensional criteria for consideration as an FDA guidance document. Members of the HBSW have developed procedures for measuring and assessing gaps in hospital bed systems in accordance with these criteria. Healthcare personnel, through participation in HBSW testing, validated the test methods and tool. The FDA has considered these HBSW recommendations in preparing this guidance.

### **Standards and Future Harmonization**

The International Electrotechnical Commission (IEC) issued an internationally recognized standard that applies to a certain segment of the products addressed in this guidance, products labeled as “powered hospital beds.” This standard is the IEC 60601-2-38, Amendment 1<sup>10</sup>. The current IEC standard recognizes that the bed frame, deck, and rails are the major elements involved in entrapment, but does not include the mattress as a contributor or mitigator and sets dimensions for new beds only. The standard also does not address safety issues associated with the use of non-electric hospital beds or the use of hospital beds in the home or in long-term care settings. The IEC standard is currently undergoing revision and will likely undergo significant change prior to its expected publication in 2007/2008. The recommendations in this FDA Guidance are similar to the IEC standard for some entrapment zones, but differ in other zones to include consideration of the mattress as part of the entrapment risk. The IEC test methods are not readily applicable for use by health care providers and are written primarily for test labs. Upon completion of the revised international bed standard, FDA will consider whether harmonization of the FDA guidance and the IEC standard is appropriate. See Appendix C for a list of National and International Entrapment Standards.

---

<sup>10</sup> International Electrotechnical Commission (IEC) 60601-2-38, Amendment 1, 1999 Medical Electrical Equipment – Part 2-38: *Particular Requirements for the Safety of Electrically-Operated Hospital Beds*.

## **Organization of this Guidance**

This guidance:

- identifies key parts of the body at risk for entrapment
- describes potential entrapment areas or zones
- recommends maximum and minimum dimensional limits of gaps or openings in hospital bed systems
- provides a scientific basis for the dimensional limits derived from a review of international anthropometric data, a review of historical entrapment data, and a retrospective study to verify the proposed dimensional limits
- provides information about reporting entrapment adverse events
- provides a copy of the HBSW test methods for assessing gaps or openings in hospital bed systems
- provides information about obtaining other HBSW documents and instructional materials

## **Scope**

The goal of the FDA Hospital Bed System Dimensional and Assessment Guidance to Reduce Entrapment is to reduce potential life-threatening entrapments associated with hospital bed systems. Because hospital bed systems that are primarily intended for one type of care setting can be moved into other care settings, the recommendations in this guidance may be appropriate for hospital beds regardless of the healthcare setting. The dimensional limits in this guidance may not reduce entrapments in all populations, e.g. pediatrics and developmentally disabled people. See the narrative below in the exclusions section.

FDA uses the term “hospital bed” in this guidance to refer to a variety of medical devices that are classified as beds. FDA regulations classify hospital beds as Class I and Class II devices (see Table 1). These devices are used for patients in acute care, long-term care, or home care settings. FDA considers stretchers that are used for extended stay in health care facilities (because they are used like hospital beds) as hospital beds for purposes of this guidance. As stated above, the term “hospital bed system” used throughout this document encompasses the bed frame and its components, including the mattress, bed side rails, head and foot board, and any accessories added to the bed. Bed rails (see footnote 8), also called “side rails,” may be an integral part of the bed frame or they may be removable and at times are used either as a restraint, a reminder or an assistive device. Bed rails may consist of one



## *Contains Nonbinding Recommendations*

full-length rail per side or one or more, shorter rails per side, may be a fixed height or adjustable in height, and may move as the head or foot sections of the bed are raised or lowered.

This guidance provides recommendations related to devices in the following table (Table 1). Class II devices are subject to design controls under the Quality System regulation. For those beds in class II, we recommend that manufacturers consider the recommendations in this guidance when developing their design controls. The recommendations in this guidance may also assist manufacturers of all devices listed in Table 1 below in manufacturing hospital beds that will minimize the risk for patient entrapment.

Table 1: Bed Systems Covered under this Guidance

Product Code	CFR Section	Classification Name	Class	510(k) Exempt
FMR	880.6785	Manual patient transfer device	I	Yes
FNJ	880.5120	Manual adjustable hospital bed	I	Yes
FNK	880.5110	Hydraulic adjustable hospital bed	I	Yes
FNL	880.5100	AC-powered adjustable hospital bed	II	Yes
FPO	880.6910	Wheeled stretcher*	II	Yes
IKZ	890.5225	Powered patient rotation bed	II	Yes
ILK	890.5150	Powered patient transport*	II	No
INK	890.3690	Powered wheeled stretcher*	II	No
INY	890.5180	Manual patient rotation bed	I	Yes
IOQ	890.5170	Powered flotation therapy bed	II	Yes

\*When labeled for extended-stay use

The recommendations in this guidance may also be useful in evaluating and reducing the risk of entrapment presented by the devices listed in Table 1 that have already been manufactured and installed (legacy beds). FDA recognizes that legacy beds have the potential for dimensional change over time through wear and tear or substitution of new mattresses and other components not contemplated in the original bed system. Because of these factors, FDA does not intend to take enforcement actions for failure to submit reports of corrections and removals under 21 CFR Part 806 for actions taken in response to this guidance that correct or improve hospital beds currently in use or held as inventory. However, manufacturers and importers should create and maintain records of these corrections and removals in accordance with 21 CFR Part 806.

Some states may have adopted special requirements for the design of hospital beds. For example, New York has adopted more stringent dimensional limits for hospital beds and twin beds used for developmentally disabled people.<sup>11</sup> The dimensions used in the FDA guidance are not intended to replace state law requirements that may exist. Moreover, some hospital beds excluded from the scope of the recommendations in this guidance may still be subject to dimensional limits under state laws.

---

<sup>11</sup> Schatz, William M., PT, Bed Safety Consulting, Inc., Comment #C2 to Docket #2004 D-0343, Draft Guidance for Industry and FDA Staff; Hospital Bed System Dimensional Guidance to Reduce Entrapment, November 10, 2004.

## *Contains Nonbinding Recommendations*

### **Articulation**

The movement of the bed deck is known as articulation. FDA recognizes that articulation of the bed introduces complex geometries that make applying the dimensional criteria to reduce entrapment difficult. Presently, the dimensional recommendations in this guidance apply to hospital beds in the flat deck position and rails in the fully raised position, except where noted. FDA recognizes that patient care also occurs while the bed is articulated and some articulated positions may pose a risk of entrapment. The Agency will continue to gather data and consider other approaches for assessing gaps in articulated beds in the future. We recommend that patient assessment procedures be used to assess the risk of entrapment when clinical care is provided in an articulated position.

### **Legacy Beds**

The issue of patient entrapment in hospital beds is complex and affects manufacturers, healthcare practitioners and facilities, medical equipment suppliers, home health agencies, patients, and caregivers. Many beds currently in use may no longer have the original mattress or bed rails, and may present an entrapment hazard by increasing or creating gaps or spaces between various components of the bed system. The recommendations in this guidance therefore apply to most hospital beds, including legacy beds in various settings where health care is provided. As described above, a new hospital bed becomes a “legacy bed” as soon as it is placed into use.

Reducing the risk of entrapment involves a multi-faceted approach that includes bed design, clinical assessment and monitoring, as well as meeting patient, resident, and family needs for vulnerable patients in most health care settings - hospitals, long term care facilities, and at home. Therefore, comprehensive bed safety programs in these settings will likely involve input from manufacturers as well as facility staff. Recognizing that not all hospital beds present a risk of entrapment, and that this risk may vary depending on the patient, FDA encourages manufacturers and facilities to work together to develop bed safety programs to evaluate and, if needed, mitigate entrapment risk.

When evaluating the safe use of a hospital bed, component or accessory, manufacturers and caregivers should recognize that the risk for entrapment may increase if a hospital bed system is used for purposes, or used in a care setting, not intended by the manufacturer. Evaluating the dimensional limits of gaps in hospital beds may be one component of a bed safety program which includes a comprehensive plan for patient and bed assessment. Bed safety programs may also include plans for the reassessment of hospital bed systems. Reassessment may be appropriate when (1) there is reason to believe that some components are worn (e.g., rails wobble, rails have been damaged, mattresses are softer) and could cause increased spaces within the bed system, (2) when accessories such as mattress overlays or positioning poles are added or removed, or (3) when components of the bed system are changed or replaced (e.g., new bed rails or mattresses).

## *Contains Nonbinding Recommendations*

FDA recommends that healthcare facilities conduct a risk-benefit analysis to ensure that steps taken to mitigate the risk of entrapment do not create different, unintended risks or reduce clinical benefits available to patients using legacy beds. Such steps may include checking with bed system manufacturers to identify compatible mattresses, rails, and accessories. Likewise, healthcare facilities may contact their equipment suppliers for entrapment mitigating solutions that may already be available. Manufacturers should follow the appropriate FDA regulations regarding risk assessment, design controls, and documentation when developing mitigation components, attachments and other accessories to address entrapment risks in legacy hospital beds.

Additional resources are available to help caregivers and health care providers assess the individual patient's needs, consider and address entrapment risks, and recommend mitigation strategies. See Appendix B for examples of additional resources.

### **Exclusions**

The dimensional criteria described on pages 15-21 are recommended for a number of products, but not all types of hospital beds. We are listing those products below for which some, or all, of the dimensional criteria are not recommended. You can find more detailed descriptions of these products in 21 CFR Parts 880 and 890. Please note that the products listed below are not free from risk of entrapment. We continue to suggest that users identify and address areas of potential entrapment for each patient or resident through a comprehensive bed safety program.

Total exclusion from the scope of this guidance:

- Air fluidized therapy beds are excluded because the nature of the therapy does not allow the patient to exit the bed easily. When these products are used, we recommend that steps are taken to ensure that the therapeutic benefit outweighs the risk of entrapment.
- Bariatric (obesity) beds, pediatric beds and infant cribs are excluded because we did not use anthropometric data for these groups in determining the recommended dimensional limits of the entrapment zones in this guidance.
- Stretchers not used for extended-stay, examination tables, operating room tables, radiology tables, proning tables, exercise and range of motion tables, bathing units, and mechanical lifting devices are excluded from the scope of this guidance because they are not ordinarily used as hospital beds.

Partial Exclusion from the scope of this guidance:

- Kinetic treatment tables and rotation beds are excluded from the dimensional limits except for those spaces within the perimeter of the rail due to the special design requirements of these beds. See Zone 1 description on page 15. When these products are used, we recommend that steps are taken to ensure that the therapeutic benefit outweighs the risk of entrapment.

## *Contains Nonbinding Recommendations*

- Labor, delivery, recovery, and postpartum (LDRP) specialty beds are excluded from the dimensional limits for the area under the rail at the end of the rail due to the special design requirements for obstetric care. See Zone 4 description on page 18.
- Pressure Reduction Therapeutic Products  
Framed flotation therapy beds, powered air mattress replacements, and similar pressure reduction products that have therapeutic benefits such as reducing pressure on skin are easily compressed by the weight of a patient and may pose an additional risk of entrapment when used with conventional hospital bed systems. When these types of mattresses compress, the space between the mattress and the bed rail may increase and pose an additional risk of entrapment. While entrapments have occurred with the use of framed flotation therapy beds (specialty air beds built into a hospital bed frame) and air mattress replacements,<sup>12, 13</sup> these products are excluded from the dimensional limit recommendations, except for those spaces within the perimeter of the rail. See Zone 1 description on page 15. This partial exemption is due to the highly compressible nature of these mattresses, which poses technical difficulties with measuring certain dimensional gaps in these types of products. We will continue to work with the IEC to develop and refine test methods to address the risk of entrapment in bed systems using these products.

Additional caution should be taken when using these products to ensure a tight fit of the mattress to the bed system. If a powered air mattress is replacing a mattress on a bed system that meets the recommendations in the guidance with the original mattress, the resulting bed system with the new air mattress may still pose a risk of entrapment. When these products are used, we recommend that steps are taken to ensure that the therapeutic benefit outweighs the risk of entrapment.

NOTE: FDA continues to recommend the dimensional limits in this guidance for bed systems using mattress overlays. We recommend that steps be taken to assess the therapeutic benefit to the patient when applying a mattress overlay to a bed system that does not meet the recommended dimensional limits. The clinical benefit should outweigh the risk of entrapment presented by use of such a system.

## **Reporting an Entrapment Adverse Event**

FDA will continue to monitor adverse event data on entrapments in hospital beds. Your complete and descriptive reports of each entrapment or near-entrapment adverse event will help FDA to monitor the safety of hospital beds. When reporting an entrapment event, manufacturers and users often leave out details of the entrapment event that can be useful in

---

<sup>12</sup> Miles SH. Deaths between Bedrails and Air Pressure Mattresses, *Journal of the American Geriatrics Society* 2002; 50:1124-5.

<sup>13</sup> Joint Commission on Accreditation of Healthcare Organizations, Issue 17 Sentinel Event Alert: *Bed Rail-Related Entrapment Deaths* (Sept. 6, 2002).

## *Contains Nonbinding Recommendations*

identifying the factors or conditions that led to the event. Consequently, these reports only tell FDA that an adverse event took place. To improve the quality of entrapment adverse event reports, the following information is important and helpful to include:

1. the exact location or zone of entrapment (the zones described in this document and Appendix D can be used to help describe entrapment events)
2. the body part that was entrapped, and, if possible, the size of the entrapped body part (i.e., head breadth, neck diameter, chest depth)
3. the position of the rails (fully raised, intermediate, or lowered)
4. type of rails in use (full length,  $\frac{3}{4}$  length,  $\frac{1}{2}$  length, split rails or  $\frac{1}{4}$  length), and the number of side rails raised at the time of the event
5. the articulation of the bed deck (which sections of the deck were raised, and the approximate degree of elevation for each deck section)
6. mattress type, mattress height, and height of the rail from the top of the mattress, and
7. information on the size of the gap that contributed to the entrapment.

More information on reporting adverse events to the FDA can be found at:  
<http://www.fda.gov/cdrh/mdr/>.

## **Key Body Parts at Risk**

Three key body parts at risk for life-threatening entrapment in the seven zones of a hospital bed system discussed in this guidance are the head, neck, and chest. International anthropometric data references have been used to determine the relative sizes of these body parts for the population at greatest risk for entrapment and to provide a guide for the dimensional limits that would reduce their risk of entrapment. See Appendix D.

### **Head**

To reduce the risk of head entrapment, openings in the bed system should not allow the widest part of a small head (head breadth measured across the face from ear to ear) to be trapped. Country-specific anthropometric data show that a 1st percentile female head breadth may be as small as 95 mm (3  $\frac{3}{4}$  inches). A dimension of 120 mm (4  $\frac{3}{4}$  inches) encompasses the 5th percentile female head breadth in all data sources used to develop these recommendations, and includes 1st percentile female head breadth as reported in some data sources.

FDA is therefore using a head breadth dimension of 120 mm (4  $\frac{3}{4}$  inches) as the basis for its dimensional limit recommendations. This dimension is consistent with the dimensions recommended by the HBSW and the IEC.

## Contains Nonbinding Recommendations

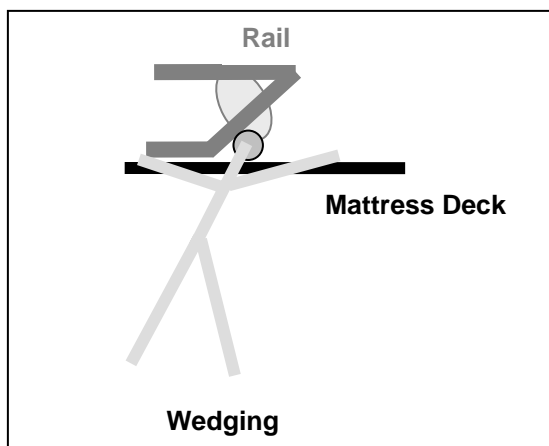

### Neck

To reduce the risk of neck entrapment, openings in the bed system should not allow a small neck to become trapped.

Data show a 1st percentile female neck diameter of 79 mm (3 1/8 inches) [5th percentile = 83 mm (3 1/4 inches)].

Several factors, such as neck compressibility, loss of muscle mass in the neck when people age, and the

asymmetrical shape of the neck, support the use of a reduced measurement. For example, one published estimate for compressibility of neck tissue is 25% of the uncompressed measure.<sup>14</sup> Reducing the 79 mm measure by approximately 25% to account for tissue compression gives a measure of 60 mm (2 3/8 inches). Both the IEC and the HBSW recommend a dimensional limit of 60 mm (2 3/8 inches) to prevent neck entrapment. Consistent with these recommendations, FDA is recommending 60 mm (2 3/8 inches) as an appropriate dimension for neck diameter.

The concept of a wedging effect, which occurs when the neck is trapped in a V-shaped opening, recurs throughout many national and international entrapment-prevention standards (See Appendix C); however, the standards differ with respect to what is considered to be the critical angle for wedging. Some standards specify minimum angles to prevent neck entrapment based on a theoretical analysis of the forces on a cylindrical object (representing the cross-section of a neck) in an angled space. Depending on whether the wedging is considered to be caused by the total resultant forces on the neck or the horizontal components of the forces, the critical angles are identified as either 60 (See Appendix C, References 5 and 6) or 53 degrees (rounded up to 55) (See Appendix C, References 1,4 and 9), respectively.

When developing its recommendations for preventing neck entrapment, HBSW consulted a published international standard for swimming pool equipment [see EN 13451], which includes dimensional limits to prevent entrapment of various body parts of adults and children. This standard specifies that V-shaped openings should be of angles greater than 60 degrees. HBSW members performed analyses that support this limit, and the HBSW has recommended that V-shaped openings be greater than 60 degrees to avoid neck entrapment.

Given the adult population at risk for wedging entrapments in hospital beds, FDA is recommending a dimension of 60 mm (2 3/8 inches) to represent neck diameter.

<sup>14</sup> ASTM International. "Standard Consumer Safety Specification for Expansion Gates and Expandable Enclosures." *Annual Book of ASTM Standards*, Vol. 15.07, Appendix X2, Designation F 1004.

*Contains Nonbinding Recommendations*

Additionally, to prevent wedging, a limit of greater than 60 degrees is recommended for V-shaped openings that a neck could enter. These dimensions are consistent with the dimensions recommended by the HBSW and the IEC (see IEC 60601-2-38-1).

**Chest**

The openings in a bed system should be wide enough not to trap a large chest through the opening between split rails. For purposes of the recommendations in this guidance, a 95<sup>th</sup> percentile male chest depth is used to represent the largest chest measure. Although one would assume that the largest chest size belongs to women, breast tissue is compressible and diminishes in size as aging occurs. Male chests, however, have less compressible tissue and do not diminish as significantly in size with aging. A 95th percentile male chest depth of 318 mm (12 ½ inches), measured from the nipple to the back, including the pectoral muscles, is used to represent the largest chest measure.

The IEC is proposing to adopt a dimension to reduce chest entrapment of greater than 318 mm (12 ½ inches). FDA concurs with the dimension of 318 mm (12 ½ inches) to represent chest depth for the population vulnerable to entrapment, and has used this dimension as the basis for its recommended dimensional limits.

**The body part dimensions used to develop FDA's dimensional limit recommendations are summarized in Table 2 below.**

<b>Table 2</b>	
<b>Key Body Part Dimensions</b>	
<b>Key Body Part</b>	<b>Dimension</b>
Head	120 mm (4 ¾ inches)
Neck	60 mm (2 3/8 inches) and an angle > 60 degree
Chest	318 mm (12 ½ inches)

## Potential Zones of Entrapment

This guidance describes seven zones in the hospital bed system where there is a potential for patient entrapment. Entrapment may occur in flat or articulated bed positions, with the rails fully raised or in intermediate positions. Descriptions of the seven entrapment zones appear on pages 15-21 in this guidance. Summary drawings of entrapment for all of the zones appear in Appendix E.

The seven areas in the bed system where there is a potential for entrapment are identified in the drawing below.

- Zone 1:** Within the Rail
- Zone 2:** Under the Rail, Between the Rail Supports or Next to a Single Rail Support
- Zone 3:** Between the Rail and the Mattress
- Zone 4:** Under the Rail, at the Ends of the Rail
- Zone 5:** Between Split Bed Rails
- Zone 6:** Between the End of the Rail and the Side Edge of the Head or Foot Board
- Zone 7:** Between the Head or Foot Board and the Mattress End

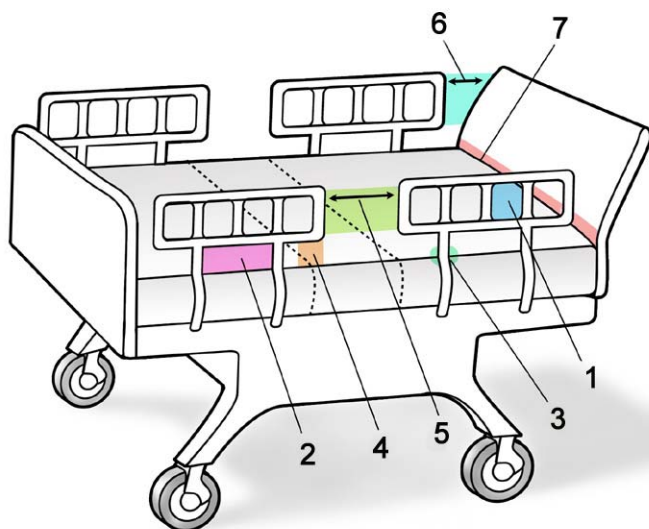

### Entrapment at the Bed Deck or Frame

Many of the entrapment event reports FDA received involved entrapment between the rail and the bed's "frame." It is unclear from the event descriptions whether this refers to the mattress deck, the bed frame, or even the hardware attaching the bedrail to the bed system. While this guidance does not recommend dimensional limits on the space at the deck or frame locations, FDA believes that meeting the other recommended dimensional limits would reduce the possibility of entrapment at the deck or frame locations.



## **A Retrospective Study of Entrapment Reports to FDA**

FDA's adverse event reporting system helps promote product safety by collecting information on products that are currently on the market. FDA's reporting system collects reports of adverse events<sup>15</sup> that caused or may have caused a death, a serious injury, or a malfunction. From January 1985 to March 2000, FDA received 390 entrapment event reports to its adverse events database from manufacturers, hospitals, nursing homes, and consumers. In 2000, HBSW reviewed these adverse event reports and identified entrapment areas or zones in the bed system and the body parts at risk. Based on its analysis of the reported adverse events, HBSW made recommendations for dimensional limits.

A retrospective study conducted by members of HBSW compared the HBSW recommended dimensions with dimensions of the bed models identified in the adverse events reports. For each of the entrapment adverse events in the study where the model number of the bed was reported, a participating bed manufacturer provided information on the dimensions of the identified area where an entrapment was believed to have occurred<sup>16</sup>. Four manufacturers provided this information. These data represented 215 (55%) of the 390 entrapment events. This information provided a reference range typical of hospital beds currently available for use in acute, long term care, and home settings.

The retrospective study compared the manufacturer-supplied information, in the aggregate, to the dimensions recommended by the HBSW. If the size of the openings in the reported bed models did not meet the HBSW recommended limits, i.e., the openings in the reported beds were outside the limits of the recommended gap sizes, then the HBSW dimensional limits were considered to be an appropriate limit to reduce entrapments at that area. We have considered the information from this study in developing the dimensional limit recommendations described in this guidance.

---

<sup>15</sup> Note: Many reports lacked a complete and detailed description of the adverse event. The beds involved in these adverse events may not have had compatible mattresses or bed rails specifically designed for the particular bed model involved in the reported entrapments. Also, information was limited regarding the condition of the beds, bed rails, and mattress at the time of the entrapments. Specific details about the exact location of the entrapments within the beds were sometimes lacking. Despite these limitations, adverse event reports can suggest a profile of the areas or locations on a hospital bed where entrapment can occur, as well as the parts of the body at risk for entrapment.

<sup>16</sup> When manufacturers measured the gaps for the retrospective study, they used mattresses of the size, type and thickness typically recommended for use with their bed models. Mattresses involved in reporting entrapment events may have been different from the manufacturers' recommended mattresses, which means actual gap sizes in entrapments involving the mattresses may have been different from those identified by the manufacturers in the retrospective study. The manufacturers' measurements may have been representative of "best case measurements." We also note that spaces in a hospital bed system may vary in size when the hospital bed system is articulated through the various ranges of motion. For the retrospective study, manufacturers measured gap sizes with the beds in the flat position. This means that if the bed was articulated in reported entrapments, the size of the gap may have been different from that provided by the manufacturers in the retrospective study.

## **Dimensional Limits for Identified Entrapment Zones 1-4**

FDA is recommending dimensional limits for zones 1 through 4 at this time because we believe the majority of the entrapments reported to FDA have occurred in these zones. We based these recommended limits upon the body parts entrapped in these individual zones identified through adverse event reports and entrapment scenarios described in the reports. A summary table (Table 3) of the hospital bed dimensional limit recommendations appears on page 21 at the end of this section.

The Hospital Bed Safety Workgroup developed and validated test methods to measure and assess gaps or openings in zones 1-4 of hospital bed systems, reprinted in Appendix F. As a member of the HBSW, FDA participated in the development and validation of these test methods. FDA recommends these test methods as an acceptable approach for assessing hospital bed gap sizes in accordance with the dimensional limitations described below. The test methods and tool used to conduct these tests are available through HBSW (see Appendix B). If an alternate approach is used to assess gap sizes, FDA recommends that the dimensional limits used in any alternative approach be at least as stringent as the ones described below.

### **Zone 1 – Within the Rail**



Zone 1 is any open space within the perimeter of the rail. Openings in the rail should be small enough to prevent the head from entering. A loosened bar or rail can change the size of the space. The HBSW and IEC recommend that the space be less than 120 mm (4 <sup>3</sup>/<sub>4</sub> inches), representing head breadth.

### **Data from the Retrospective Study**

Adverse events identified as occurring within the rail were reported in bed models where open spaces within the rail were greater than 120 mm (4 <sup>3</sup>/<sub>4</sub> inches). Manufacturers' measurements of bed models representative of those identified in these incidents had spacing within the rail of between 177 mm (6.97 inches) and 190 mm (7.48 inches). The data suggest that nearly all of these entrapment events may have been prevented if the spaces within the rails had been less than 120 mm (4 <sup>3</sup>/<sub>4</sub> inches), representing head breadth as described above. Consistent with HBSW's and the IEC's recommendations and comments received on the

## *Contains Nonbinding Recommendations*

previously published draft FDA guidance, FDA is recommending a measure of less than 120 mm (4 ¾ inches) as the dimensional limit for any open space within the perimeter of a rail. The space should not permit an object with a circular cross-section measuring less than 120 mm (4 ¾ inches) in diameter to enter or pass through.

### **Zone 2 – Under the Rail, Between the Rail Supports or Next to a Single Rail Support**



This space is the gap under the rail between a mattress compressed by the weight of a patient's head and the bottom edge of the rail at a location between the rail supports, or next to a single rail support. If there is a single rail support, entrapment in Zone 2 can occur anywhere along the bottom length of the rail beyond the support, up to the end of the rail. (Entrapment at the end of the rail is explained in Zone 4.) Factors to consider are the mattress compressibility<sup>17</sup> which may change over time due to wear, the lateral shift of the mattress or rail, and any degree of play from loosened rails or rail supports. A restless patient may enlarge the space by compressing the mattress beyond the specified dimensional limit. This space may also change with different rail height positions and as the head or foot sections of the bed are raised and lowered. The space may increase, decrease, become less accessible, or disappear entirely. In some positions, the potential for entrapment in this zone may still exist when the deck is articulated.

Preventing the head from entering under the rail would most likely prevent neck entrapment in this space. FDA recommends that this space be small enough to prevent head entrapment, less than 120 mm (4 ¾ inches). IEC recommends the same dimensions but measures the space without the mattress in place.

### **Data from the Retrospective Study**

In the study, the manufacturers were instructed to measure diagonally from the top edge of the compressed mattress to the lowest inside edge of the rail between the rail supports. This

---

<sup>17</sup> "Mattress compressibility" refers to the extent to which a mattress changes in dimension as a result of the weight of a patient's body or body part moving on, across, or off of the mattress surface. The mattress dimension may also change as a result of articulation of the deck.

## *Contains Nonbinding Recommendations*

measurement ranged from between 76 mm (3 inches) and 191 mm (7.5 inches). If the reported entrapments occurred at Zone 2, the data suggest that the HBSW recommended dimensional limit of less than 120 mm (4 ¾ inches) would have prevented only about half of the reported events at this zone. At times, the adverse event report information was not clear, and it was difficult to determine the precise location of the entrapment and to determine whether it occurred in Zone 2, 3, or 4. Most reports only stated that an entrapment occurred “between the rail and the mattress.” However, given the scenarios in the reports, some of these events may have occurred at the rail end, beyond the support (Zone 4) as neck entrapments when the head entered under the rail first.<sup>17</sup>

Because the data for reported entrapments at Zone 2 are not definitive and the most likely scenario for entrapment in this space would include a head-first entry, the dimensional limit of 120mm (4 ¾ inches) is being recommended.

### **Zone 3 – Between the Rail and the Mattress**



This area is the space between the inside surface of the rail and the mattress compressed by the weight of a patient’s head. The space should be small enough to prevent head entrapment when taking into account the mattress compressibility, any lateral shift of the mattress or rail, and degree of play from loosened rails. HBSW and IEC recommend a dimension of less than 120 mm (4 ¾ inches) because the head is presumed to enter the space before the neck. FDA is recommending a dimensional limit of less than 120 mm (4 ¾ inches) for the area between the inside surface of the rail and the compressed mattress.

### **Data from the Retrospective study**

A review of the manufacturers’ supplied measurements indicates that the horizontal gap between the rail and the uncompressed mattress for bed models involved in entrapments believed to have occurred at Zone 3 was between 38 mm (1 ½ inches) and 127 mm (5 inches). Theoretically, entrapment would involve compression of the mattress which would have resulted in a larger gap than the manufacturer measurements without patients present and, subsequently, a larger range of measures. Further, it could not be determined from the description of entrapment events whether entrapments occurred at Zones 2, 3 or 4. FDA recommends a 120mm (4 ¾ inch) dimensional limit for this zone based on the head breadth dimension described above.

## **Zone 4 – Under the Rail at the Ends of the Rail**



This space is the gap that forms between the mattress compressed by the patient, and the lowermost portion of the rail, at the end of the rail. Factors that may increase the gap size are: mattress compressibility, lateral shift of the mattress or rail, and degree of play from loosened rails. The space poses a risk for entrapment of a patient's neck. It may change with different rail height positions and as the head or foot sections of the bed are raised and lowered. The space may increase, decrease, become less accessible, or disappear entirely. Thus, in some positions, the potential for entrapment in this zone may still exist when the deck is articulated.

At the time of this publication, the IEC international standard recommends a dimensional limit of less than 60 mm (2 3/8 inches) measured between the mattress support platform and the lowest portion of the rail at the rail end to prevent neck entrapment. Based on the neck diameter dimension described above, FDA recommends that the dimensional limit for this space also be less than 60 mm (2 3/8 inches). To reduce the risk of neck entrapment at Zone 4, FDA recommends consideration of the combination of the gap size and the angle size (created between the mattress and the rail). Thus, FDA recommends that the V-shaped opening under the rail at its end be of an angle wide enough, i.e. greater than 60 degrees, to prevent wedging entrapment (See Neck Section on pages 11 and 12 for a description and diagram of wedging entrapments).

### **Data from the Retrospective Study**

The retrospective study measures for Zone 4 ranged between 102 mm (4 inches) and 152 mm (6 inches) for the diagonal measure between the inside bottom edge of the rail at the end of the rail and the top of the compressed mattress. It could not be determined from the entrapment event reports whether the entrapments occurred in Zone 4, or whether events reported as neck entrapment occurred as a result of head-first entry. The HBSW recommended that a 60 mm dimension be used to represent neck diameter. Later the HBSW identified the importance of avoiding wedging of the neck at the end of the rail, and concluded that a linear measure for the Zone 4 space would not adequately address mattress compressibility and wedging forces in Zone 4. HBSW recommended that openings in Zone 4 measure both less than 60 mm in size and greater than 60 degrees in angle. FDA agrees with this recommendation.

## *Contains Nonbinding Recommendations*

### **Zones 5, 6 and 7**

Although seven potential zones of entrapment have been identified by HBSW, FDA is recommending dimensional limits for zones 1-4 because these zones were most frequently reported as having entrapments. The current international standard (IEC 60601-2-38) addresses limits for zones 1, 2, 4, and 6. In addition, IEC intends to set or revise dimensional limits, for areas comparable to HBSW's zones 1-6 in their upcoming international standard for hospital beds. FDA continues to receive entrapment reports for Zones 5 and 6, and Zone 7 remains a potential for entrapment. FDA will monitor entrapments in these zones and consider harmonization with the IEC standard once it is available.

#### **Zone 5 – Between Split Bed Rails**



This zone occurs when partial length head and foot side rails (split rails) are used on the same side of the bed. The space between the split rails may present a risk of either neck entrapment or chest entrapment between the rails if a patient attempts to, or accidentally, exits the bed at this location. In addition, any V-shaped opening between the rails may present a risk of entrapment due to wedging. FDA recognizes this area as a potential for entrapment and encourages facilities and manufacturers to report entrapment events at this zone.

#### **Zone 6 – Between the End of the Rail and the Side Edge of the Head or Foot Board**



Zone 6 is the space between the end of the rail and the side edge of the headboard or footboard. This space may present a risk of either neck entrapment or chest entrapment. In

### *Contains Nonbinding Recommendations*

addition, any V-shaped opening between the end of the rail and the head or footboard may present a risk of entrapment due to wedging. This space may change when raising or lowering the head or foot sections of the bed. This space may increase, decrease, become less accessible, or disappear entirely. Thus, in some positions, the potential for entrapment may exist when the deck is articulated. FDA recognizes this area as a potential for entrapment and encourages facilities and manufacturers to report entrapment events at this zone.

#### **Zone 7 – Between the Head or Foot Board and the End of the Mattress**

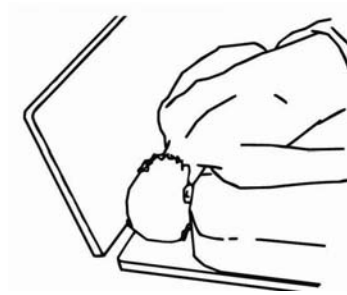

Zone 7 is the space between the inside surface of the head board or foot board and the end of the mattress. This space may present a risk of head entrapment when taking into account the mattress compressibility, any shift of the mattress, and degree of play from loosened head or foot boards. FDA recognizes this area as a potential for entrapment and encourages facilities and manufacturers to report entrapment events at this zone.

*Contains Nonbinding Recommendations*

**Table 3 Summary of FDA Hospital Bed Dimensional Limit Recommendations**

<b>Zone</b>	<b>Dimensional Limit Recommendations</b>
1 Within the rail	<120 mm (< 4 3/4 “)
2 Under the rail, between rail supports or next to a single rail support	< 120 mm (< 4 3/4 “)
3 Between rail and mattress	<120 mm (< 4 3/4 “)
4 Under the rail, at the ends of the rail	<60 mm (< 2 3/8 “) AND >60° angle



## **APPENDIX A**

### **List of Hospital Bed Safety Workgroup (HBSW) Participating Organizations**

- AARP
- American Association of Homes and Services for the Aging
- American Health Care Association
- American Medical Directors Association
- American Nurses Association
- American Society for Healthcare Risk Management/American Hospital Association
- Basic American Metal Products
- Beverly Enterprises, Inc.
- Bilanx Consulting LLC
- Care Providers of Minnesota
- Carroll Healthcare, Inc.
- ECRI
- ElderTech Solutions, LLC
- Exceptional Parent Foundation For Education
- Evangelical Lutheran Good Samaritan Society
- Hard Manufacturing Co., Inc.
- HealthSafe Inc.
- Hill Rom, Inc.
- Huntleigh Healthcare
- Iona Senior Services
- Kinetic Concepts, Inc.
- Law Offices of Julie A. Braun
- Lockwood Consulting, LLC
- Medical Devices Bureau, Health Canada
- M.C. Healthcare Products
- National Association for Home Care
- National Citizens Coalition for Nursing Home Reform
- National Patient Safety Foundation/American Medical Association
- Posey Company
- RN+ Systems / Tactilitics, Inc.
- Span-America Medical Systems, Inc.
- Stryker Medical
- Sunrise Medical, Inc.
- The ROHO Group, Inc.
- Untie the Elderly, The Kendal Corporation
- U.S. Department of Veterans Affairs
- U.S. Food and Drug Administration
- Vail Products Inc.

#### **Consulting Organizations to the Hospital Bed Safety Workgroup**

- Joint Commission on Accreditation of Healthcare Organizations
- U.S. Centers for Medicare & Medicaid Services
- U.S. Consumer Product Safety Commission

## **APPENDIX B**

### **Additional Information and Kit Information**

#### **Websites:**

Food and Drug Administration:

<http://www.fda.gov/cdrh/beds>

Bureau of Medical Devices, Health Canada:

[http://www.hc-sc.gc.ca/hpfb-dgpsa/tpd-dpt/index\\_advisories\\_professionals\\_e.html](http://www.hc-sc.gc.ca/hpfb-dgpsa/tpd-dpt/index_advisories_professionals_e.html)

ECRI:

[http://www.ecri.org/Patient\\_Information/Patient\\_Safety/BedSafetyClinicalGuidance.pdf](http://www.ecri.org/Patient_Information/Patient_Safety/BedSafetyClinicalGuidance.pdf)

HealthSafe, Inc.:

<http://www.healthsafe.org/>

Untie the Elderly, Kendal Corporation:

<http://www.ute.kendal.org>

American Association of Homes and Services for the Aging:

<http://www.aahsa.org>

American Health Care Association:

<http://www.ahca.org>

#### **Kit Information:**

The HBSW Bed Safety Entrapment Kit will be available through National Safety Technologies at <http://www.nst-usa.com>. The kit will include:

#### Documents

- *A Guide to Bed Safety* (a brochure) from the Hospital Bed Safety Workgroup
- *Clinical Guidance and Decision Tree for the Assessment and Implementation of Bed Rails in Hospitals, Long Term Care Facilities and Home Care Settings* from the Hospital Bed Safety Workgroup
- *Dimensional Test Methods for Bed Systems* from the Hospital Bed Safety Workgroup
- *Instructional Video/DVD for bed measurement*
- *A Guide for Modifying Bed Systems and the Use of Accessories to Reduce the Risk of Entrapment* from the Hospital Bed Safety Workgroup

#### Test tool kit

#### **Educational videotapes:**

- An educational videotape, *Do No Harm – Hospital Bed Safety*, explaining hospital bed and bed rail safety issues is produced by AARP. The AARP video is available through The Kendal Corporation. Ordering information can be obtained from <http://www.ute.kendal.org/>

## **APPENDIX C**

### **References for National and International Entrapment Standards**

1. ASTM International. “Standard Consumer Safety Performance Specification for Playground Equipment for Public Use.” Annual Book of ASTM Standards, Vol. 15.07, Designation F 1487.
2. ASTM International. “Standard Consumer Safety Specification for Expansion Gates and Expandable Enclosures.” Annual Book of ASTM Standards, Vol. 15.07, Designation F 1004.
3. ASTM International. “Standard Consumer Safety Specification for Bunk Beds.” Annual Book of ASTM Standards, Vol. 15.07, Designation F1427.
4. U.S. Department of the Army. “Child Development Center Play Area Inspection and Maintenance Program.” Publication No. TM 5-663.  
Public domain document available at [www.army.mil](http://www.army.mil)
5. European Committee for Standardization. “Playground Equipment – Part 1: General Safety Requirements and Test Methods.” Ref. No. EN 1176-1.  
Adopted and published under various national designations by 28 member countries of CEN, including France, Great Britain, Germany, and Sweden.
6. European Committee for Standardization. “Swimming Pool Equipment – Part 1: General Safety Requirements and Test Methods.” Ref. No. EN 13451-1.  
Adopted and published under various national designations by 25 member countries of CEN, including France, Great Britain, Germany, and Sweden.
7. 16 CFR Part 1213, “Safety Standard for Entrapment Hazards in Bunk Beds.”
8. 16 CFR Part 1513, “Requirements for Bunk Beds.”
9. U.S. Consumer Product Safety Commission. “Handbook for Public Playground Safety.” Publication No. 325.  
Public domain document, available at [www.cpsc.gov](http://www.cpsc.gov)

## **APPENDIX D**

### **Anthropometric References**

#### **Anthropometric References used:**

Hall, Judith. Handbook of normal physical measurements. New York : Oxford University Press, 1990.

[Note: Head width and neck circumference data for both sexes, -2SD (2.5th percentile), from birth to age 16. Data visually extrapolated from graphs.]

Jurgens, H., Pieper, U. International data on anthropometry. Geneva, Switzerland : International Labour Office, 1990. (Occupational safety and health series; no. 65).

[Note: This report reviewed data for North America, Latin America (Indian population), Latin America (European and Negroid population, Northern Europe, Central Europe, Eastern Europe, South-Eastern Europe, France, Iberian Peninsula, North Africa, West Africa, South-Eastern Africa, Near East, North India, South India, North Asia, South China, South-East Asia, Australia (European Population), Japan.]

Peebles, Laura, Norris, Beverly J. Adultdata - The handbook of adult anthropometric and strength measurements: data for design safety. London : Department of Trade and Industry, 1998.

[Note: This handbook contains data from various sources for the following countries: UK, Brazil, France, Germany, Italy, Japan, Poland, Sri Lanka, Sweden, Netherlands, and USA. Data were not available from ALL these countries for EACH measurement.]

Smith, Stuart, Norris, Beverly, Peebles, Laura. Older adult data – The handbook of measurements and capabilities of the older adult: data for design safety. London : Department of Trade and Industry, 2000.

[Note: This handbook contains data from various sources for the following countries: UK, Brazil, France, Germany, Italy, Japan, Poland, Sri Lanka, Sweden, Netherlands, and USA. Data were not available from ALL these countries for EACH measurement.]

Snyder, JRG. Anthropometry of infants, children and youths to age 18 for product safety design: final report. Bethesda, MD : Consumer Product Safety Commission, 1977.

#### **Others references consulted:**

Association for the Advancement of Medical Instrumentation. Human factors engineering guidelines and preferred practices for the design of medical devices. 2<sup>nd</sup> ed. Arlington, VA : Association for the Advancement of Medical Instrumentation, 1993 ; AAMI HE-48 1993.

British Standards Institution. 1987 Ergonomics – standards and guidelines for designers. United Kingdom : British Standards Institution, 1987 ; document no. PP 7317.

*Contains Nonbinding Recommendations*

Damon, Albert, Stoudt, Howard W., McFarland, Ross A. The human body in equipment design. Cambridge, MA : Harvard University Press, 1966.

Diffrient, Niels. Humanscale one-two-three. Cambridge, MA : MIT Press, 1974.

Human engineering design data digest. Washington, DC : U.S. Government Printing Office, 1975.

National Center for Health Statistics. Weight, height, and selected body dimensions of adults, United States, 1960-62. Hyattsville, MD: National Center for Health Statistics, 1980; DHHS publication no. (PHS) 80-1301. Vital and health statistics; series 11, no. 8.

Salvendy, Gavriel, ed. Handbook of human factors. New York : John Wiley & Sons, 1987.

Woodson, Wesley E. Human factors design handbook : information and guidelines for the design of systems, facilities, equipment and products for human use. New York : McGraw-Hill Book Company, 1981.

Woodson, Wesley E., Conover, Donald W. Human engineering guide for equipment designers. 2<sup>nd</sup> ed. Berkeley, CA : University of California Press, 1970.

Woodson, Wesley E., Tillman, Peggy, Tillman, Barry. Human factors design handbook. 2<sup>nd</sup> ed. New York : McGraw-Hill Professional, 1992.

## APPENDIX E

### Drawings of Potential Entrapment in Hospital Beds

**Zone 1 – Entrapment within the rail**



**Zone 2 – Entrapment under the rail, between the rail supports or next to a single rail support**

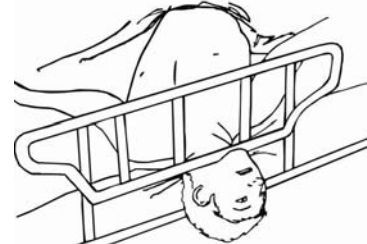

**Zone 3 – Entrapment between the rail and the mattress**



**Zone 4 – Entrapment under the rail, at end of rail**



**Zone 5 – Entrapment between split bed rails**



**Zone 6 – Entrapment between the end of the rail and the side edge of the head or foot board**



**Zone 7 – Entrapment between head or foot board and the mattress end**

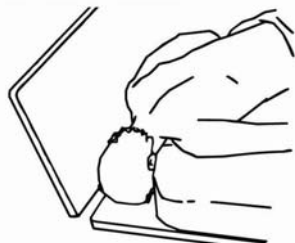

*Contains Nonbinding Recommendations*

**APPENDIX F**  
**Hospital Bed Safety Workgroup**  
**Dimensional Test Methods for Bed Systems**

## Dimensional Test Methods for Bed Systems



July 2005

### **Introduction**

The Hospital Bed Safety Workgroup (HBSW) and the U.S. Food and Drug Administration (FDA) have defined seven numbered "zones" or spaces in and around hospital bed systems where patients could potentially become trapped. Actual entrapments have been reported in six of these zones, with Zones 1, 2, 3, and 4 accounting for approximately 80% of entrapment events reported to the FDA. This appendix contains instructions for testing Zones 1, 2, 3, and 4, using tools and methods developed by the HBSW.

### **Contents**

<b>Summary of Test Zones .....</b>	<b>2</b>
<b>Description of Test Tools .....</b>	<b>3</b>
Cone and Cylinder Tool.....	3
Tool Assembly and Disassembly.....	3
Using the spring scale.....	4
<b>General Testing Considerations .....</b>	<b>4</b>
<b>Test Methods</b>	
Zone 1 Test.....	5
Zone 2 Test.....	6
Zone 3 Test.....	8
Zone 4 Test.....	10
<b>Appendix: Testing Tips and Frequent Questions .....</b>	<b>12</b>
<b>SAMPLE DATASHEETS.....</b>	<b>17</b>



## Contains Nonbinding Recommendations

### Summary of Test Zones

The four (4) tests in these instructions measure gaps within bed systems where a patient could become trapped. Each test measures a different area, or zone, where entrapment can occur:

#### **Zone 1:** Within the rail

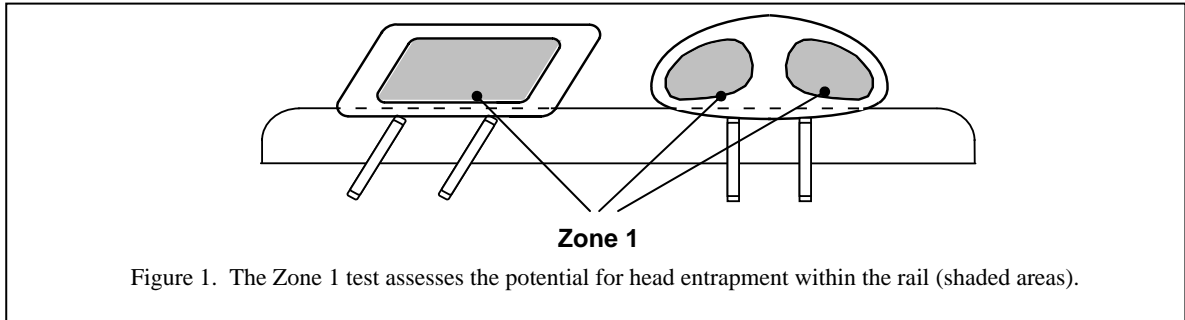

#### **Zone 2:** Under the rail between the rail supports or next to a single support

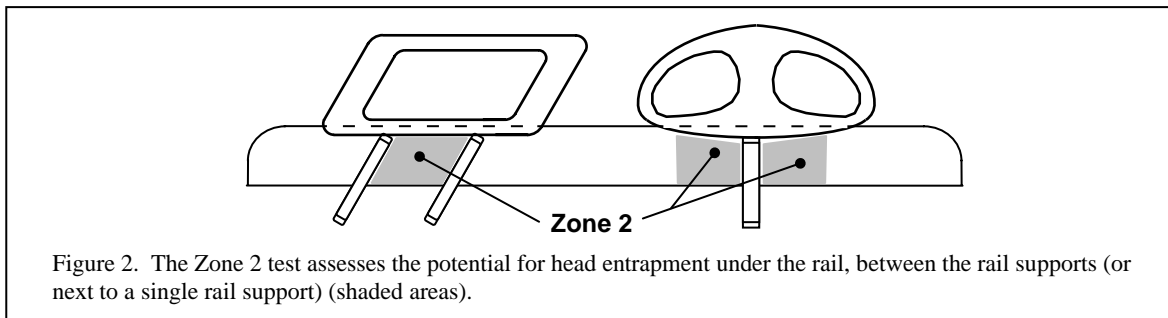

#### **Zone 3:** Between the rail and the mattress

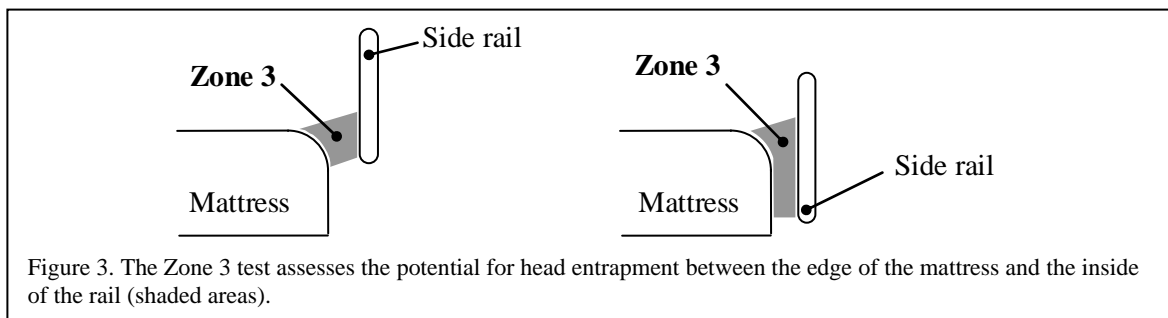

#### **Zone 4:** Under the rail at the end of the rail

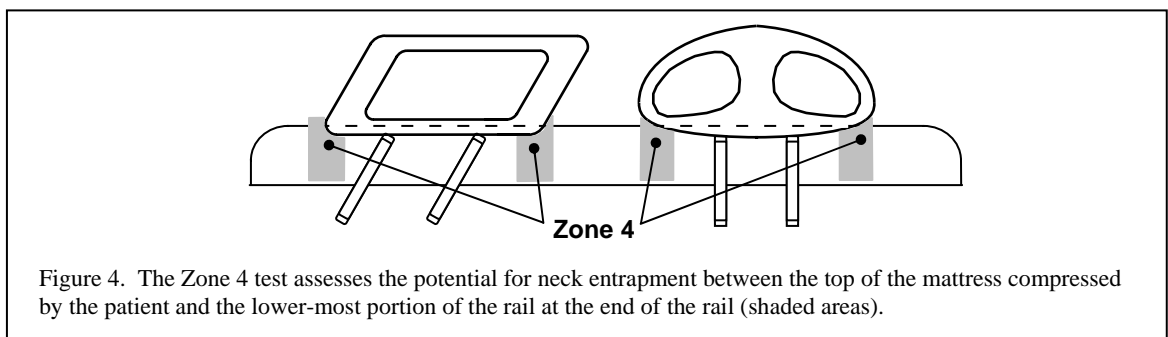

## *Contains Nonbinding Recommendations*

### **Description of Test Tools**

Each test requires the use of simple tools, including a cone, a cylinder, and a spring scale. Your tools may look slightly different from the tools in the figures, but they will work the same way.

### **Cone and Cylinder Tool**

The cone and cylinder is a combination tool (see Figure 5). It can be easily taken apart so that the cone and cylinder can be used separately. Tests 1, 2 and 3 use only the cone. Test 4 uses the combined assembled tool.

- The diameter of the large end of the cone represents the width of a small adult head (120 mm, or approximately 4 ¾ inches).
- The diameter of the cylinder represents the size of a small adult neck (60 mm, or approximately 2 ⅜ inches).
- The cone and cylinder together weigh 15 lbs. This represents the combined weight of an adult head (12 lbs.) and neck (3 lbs.).
- The red area of the cylinder defines contact angles in which the neck could become wedged (60 degrees or narrower),

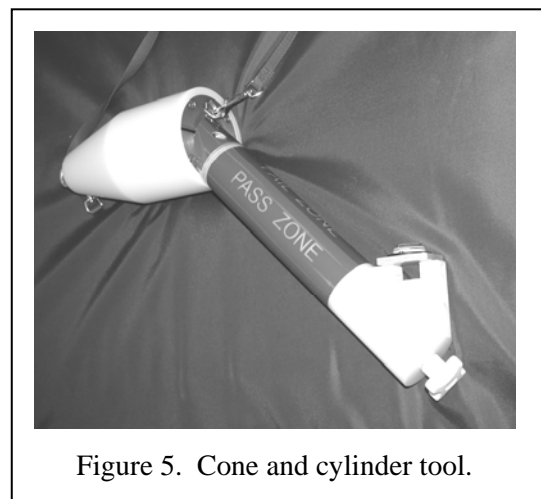

Figure 5. Cone and cylinder tool.

The cone tool includes the following features:

- A loop at the end for attaching a spring scale.
- A safety strap.
- A marked center line on the large face of the cone.

The cylinder includes the following features:

- Red and green zones for identifying pass/fail at siderail ends.
- A level to aid in tool positioning.

To prevent personal injury during the measurement process, attach the strap to a secure point on the bed and shorten the length of the safety strap enough to keep the tool from dropping on your feet if it should fall during a test. Make sure the strap is long enough to not interfere with the test measurement.

### **Tool Assembly and Disassembly**

*Note:* General procedures for tools with a screw-type connection are described here. (Your tool may have a different type of connection.) Follow the instructions supplied with your tools for more detailed information.

#### **To take the cone and cylinder tool apart:**

1. Turn the knob to loosen and remove the connection shaft.
2. Pull the cylinder from the cone.

#### **To put the cone and cylinder tool together:**

1. Align the red and green areas of the cone and cylinder.
2. Insert the pins of the cone into the cylinder.
3. Insert the connection shaft and turn the knob to tighten.

## Contains Nonbinding Recommendations



Figure 6. Disassembly and assembly of the cone and cylinder tool.

### **Using the spring scale**

Use the spring scale to apply 12 lbs of force to the cone when testing Zones 1 and 2. At the small end of the cone tool, insert the scale hook into the metal loop. Pull the scale slowly until the needle points to 12 lbs.

For other types of scales (sliders, digital, etc.), and for information on scale calibration, consult the instructions supplied with your toolkit.



Figure 7. Use of spring scale.

### **General Testing Considerations**

- *Bed Occupancy:* For ease of mattress movement and measurement, and general safety, the patient should not be in the bed during the measurement procedures.
- *Bed Height:* To avoid unnecessary bending or back strain, position the bed at a comfortable working height.
- *Bed Wheels:* To prevent movement of the bed during testing, lock the wheels.
- *Linens/Sheets:* Perform the tests with sheets in place as is typical for patient care. Remove any pillows and blankets.
- *Infection Control:* To avoid cross-contamination, disinfect the tools each time a different bed is measured. Follow the supplier's recommendations for tool disinfection.
- *Personal Safety:* To avoid injury, use care when pulling the tool through openings in the bed rails. If the tool suddenly pulls through, you could lose your balance and fall. Always use the safety strap to keep the tool from injuring your feet if it falls.
- *Intermediate Rail Position:* Some rails have an intermediate stopping position or a high and low locking position. Follow the individual test instructions, which may require testing the rails at both positions.
- *Bed Position:* Most tests should be done with the bed in the flat position. The exception is the test for Zone 2. Follow the individual test instructions carefully.
- *Testing Tips:* Consult the Appendix for helpful information.

## Contains Nonbinding Recommendations

### Zone 1 Test

*This test assesses the potential for head entrapment within the perimeter of the rail.*

The tools needed to do this test are the cone, the safety strap and the spring scale.

#### Prepare for the Zone 1 Test:

1. Lock the wheels.
2. Put the bed in the flat, horizontal position.
3. Fully raise all bed rails.
4. Position the bed at a comfortable working height.

#### Do the Zone 1 Test:

1. With the cone resting on mattress, attach the safety strap of the cone to the rail being tested. *Make sure the strap is short enough to keep the tool from injuring your feet if it falls, and long enough so it does not interfere with the test.*
2. From inside the rail, insert the cone, small end first, into the largest opening in the rail. Try to pull the tool through the space (figure 8).
3. If the tool **does not** pull through freely, attach the spring scale to the loop on the small end of the cone. Try to pull the cone through the rail by pulling on the attached spring scale using 12 lbs. of force. *Use care when pulling. If the tool suddenly pulls through the opening, you may lose your balance and fall, or the tool may fall on you.*
4. Repeat steps 2 and 3 to check all other openings within the same rail.
5. Interpret test result.

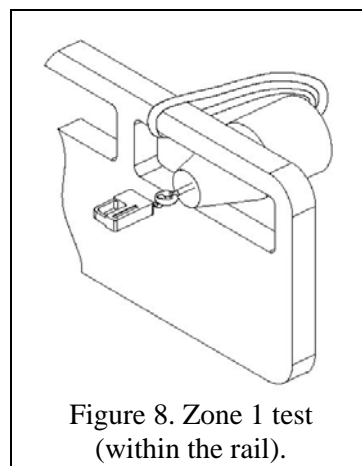

Figure 8. Zone 1 test (within the rail).

#### Interpret the Zone 1 Results:

If the large end of the cone **does not** enter any of the openings, this space **passes** the test (figure 9a).

If the large end of the cone **does** enter or pass through any of the openings, this space **fails** the test (figure 9b).

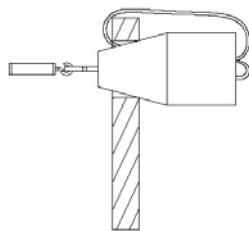

Figure 9a. Zone 1 test: **Pass**, large end of cone **does not** enter rail opening.

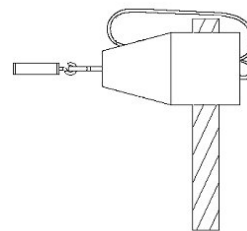

Figure 9b. Zone 1 test: **Fail**, large end of cone **does** enter rail opening.

#### Repeat the Zone 1 Test:

*On the other rails:* Repeat the test for all other rails on the bed.

## Contains Nonbinding Recommendations

### Zone 2 Test

*This test assesses the potential for head entrapment under the rail, at a location between the rail supports or next to a single support.*

The tools needed to do this test are the cone, the safety strap and the spring scale.

#### Prepare for the Zone 2 Test:

1. Lock the wheels.
2. Fully raise all bed rails.
3. Position the bed at a comfortable working height.

#### Do the Zone 2 Test:

1. Firmly push the mattress away from the rail being measured until it stops.
2. Identify the space where the test will be done (see Figure(s) 10a and 10b).
3. Determine whether the bed will be tested in the flat position or a different position:
  - Raise and lower the head and foot sections of the bed while you observe the space that will be tested.
  - **If the space(s) where the test will be done becomes smaller or does not change as the bed moves**, do the test with the bed in the flat position. (See the Appendix for examples.)
  - **If the space(s) becomes larger as the bed moves**, find the bed position that creates the largest space. Perform the test with the bed in the position where the space is the largest. (See the Appendix for an example.)
4. Attach the safety strap of the cone to the rail being tested. **Make sure** the strap is short enough to keep the tool from injuring your feet if it falls, and long enough so it does not interfere with the test.
5. From the inside of the rail, insert the cone, small end first, into the gap between the mattress and the lower edge of the rail, between the rail supports. Let the cone compress the mattress. **Do not** force the cone into the area.
6. Attach the spring scale to the loop on the cone.
7. Pull on the spring scale with **12 lbs** of force at any angle that increases the chances of the cone going through the space. **Use care** when pulling. If the tool suddenly pulls through the opening, you may lose your balance and fall, or the tool may fall on you. Observe whether the large end of the cone enters through the opening.
8. Interpret test result.

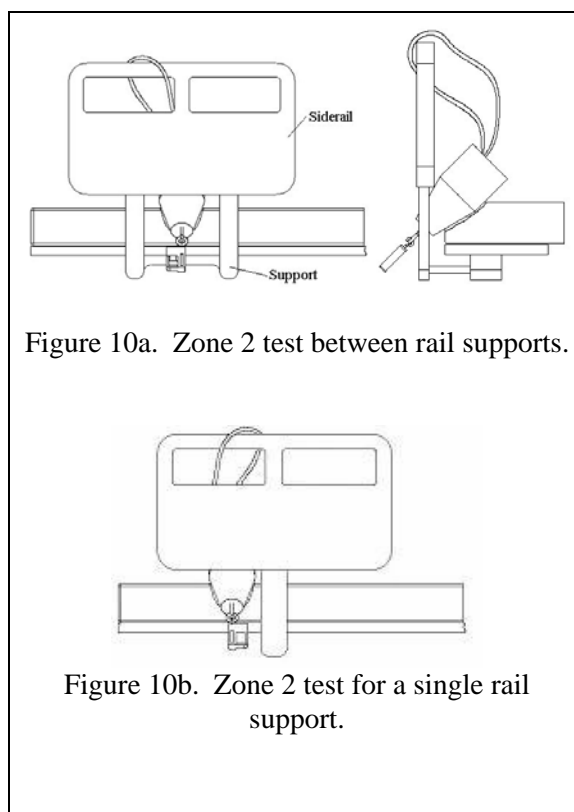

## *Contains Nonbinding Recommendations*

### **Interpret Zone 2 Test Results:**

If the large end of the cone **does not** enter the space under the rail, or pass under the rail, this space **passes** the test (figures 11a and 11b).

If the large end of the cone **does** enter the space under the rail, or if it passes under the rail, this space **fails** the test (figures 11c and 11d).

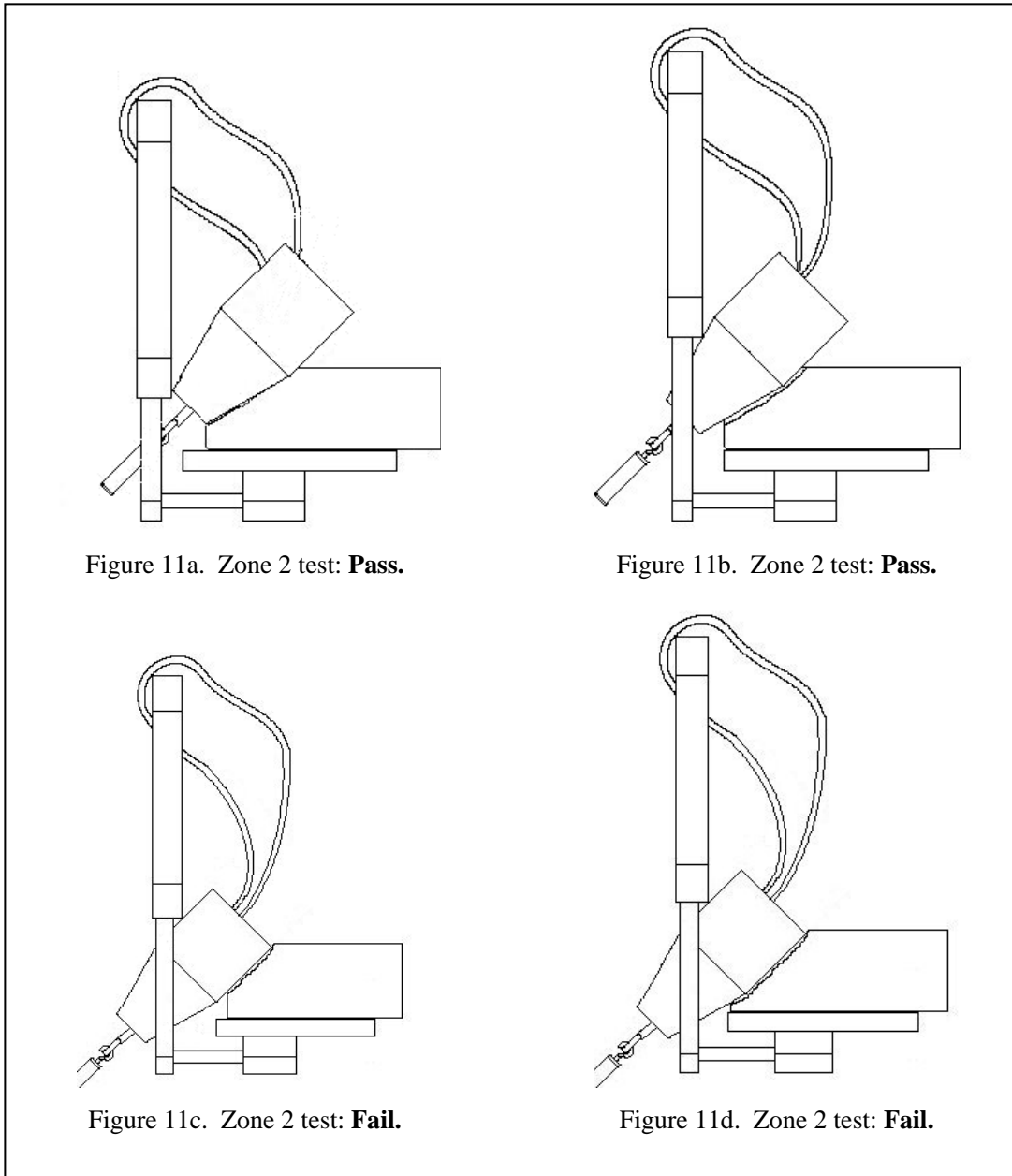

### **Repeat the Zone 2 Test:**

*On the same rail:* If the rail has intermediate locking positions, perform the test for every intermediate position.

*On the other rails:* Perform the test for all other rails on the bed, including intermediate and raised positions.

## Contains Nonbinding Recommendations

### Zone 3 Test

*This test assesses the potential for head entrapment between the inside of the rail and the surface of the mattress (compressed by the weight of a patient's head).*

The tools needed for this test are the cone and the safety strap.

#### Prepare for the Zone 3 Test:

1. Lock the wheels.
2. Put the bed in the flat, horizontal position.
3. Fully raise all bed rails.
4. Position the bed at a comfortable working height.

#### Do the Zone 3 Test:

1. Firmly push the mattress away from the rail being measured until it stops.
2. Put the cone near the rail being tested and attach the safety strap. *Make sure the strap is short enough to prevent the tool from injuring your feet if it falls, and long enough so it does not interfere with the test.*
3. Gently place the cone horizontally in the gap (figure 12a). **Do not** push the tool down into the gap.
4. Turn the cone until the line on the face of the large end is horizontal (figure 12b).
5. Let the cone sink into the space by its own weight. If the cone is tilted, use one hand to gently level it (figure 12c). **Do not** push the tool down into the gap.

**Note:** If a mattress stop, rail support, or other structure keeps the cone from sinking in the gap, put the cone tool at a different location along the rail where there is no interference.

6. Determine whether the cone's center line is above or below the surface of the mattress.
7. Interpret test result.

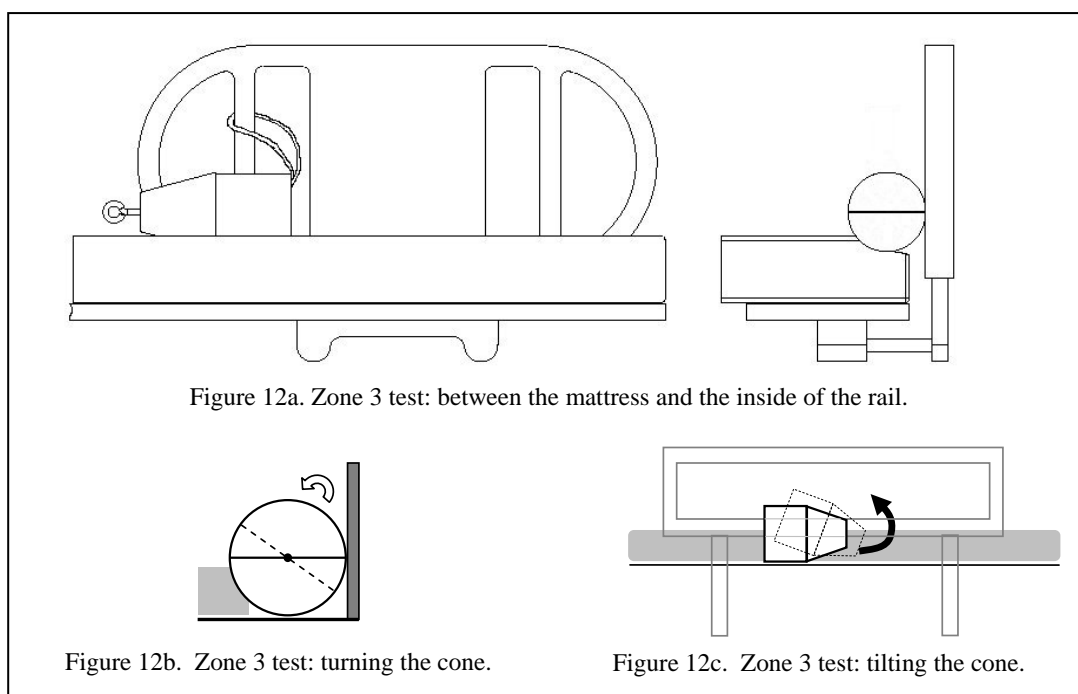

*Contains Nonbinding Recommendations*

**Interpret Zone 3 Test Results:**

If the line across the flat end of the cone is **above** the surface of the mattress, the space **passes** the test (figure 13a).

If the line across the flat end of the cone is **at or below** the top surface of the mattress, the space **fails** the test (figure 13b).

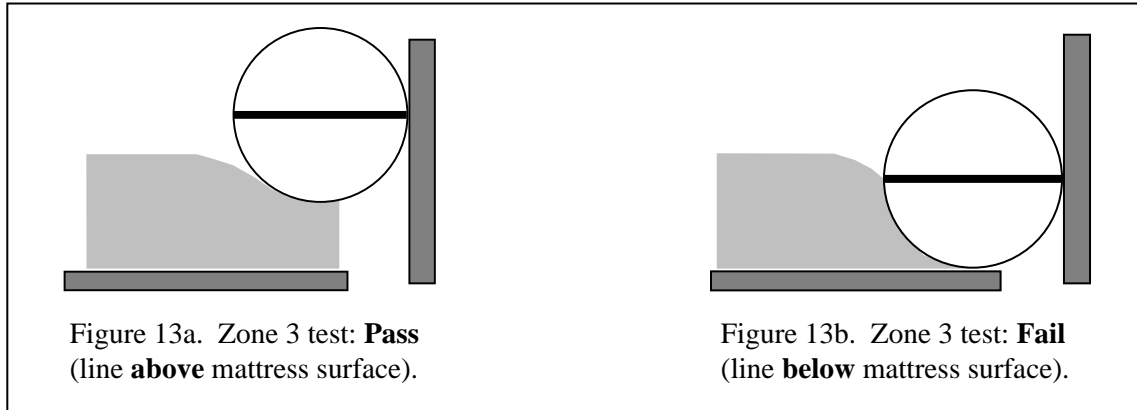

**Repeat the Zone 3 Test:**

*On the same rail:* If the rail has any intermediate positions, perform the test at every intermediate position.

*On the other rails:* Perform the test for all other rails on the bed, including the intermediate positions.



## Contains Nonbinding Recommendations

### Zone 4 Test

*This test assesses the potential for neck entrapment between the top of the mattress (compressed by the patient) and the lower-most portion of the rail, at the end of the rail.*

The tools needed for this test are the assembled cone and cylinder with safety strap.

#### Prepare for the Zone 4 Test:

1. Lock the wheels.
2. Put the bed in the flat, horizontal position.
3. Fully raise all bed rails.
4. Position the bed at a comfortable working height.

#### Do the Zone 4 Test:

1. Firmly push the mattress away from the rail being tested until it stops.
2. Attach the safety strap of the cone tool to the rail being tested. *Make sure the strap is short enough to prevent the tool from injuring your feet if it falls, and long enough so it does not interfere with the test.*

3. Just beyond the end of the rail, rest the cone portion of the cone and cylinder tool on the mattress. The test area is shown in Figure 14. (If the bed has split rails, you may need to lower the rail next to the one being measured to make room for the tools.)

**Note:** If the cylinder tool **cannot fit** into an area between the head or footboard and the end of a rail, the space **passes**.

4. Position the tool so that the large face of the cone is flush or even with the edge of the mattress (figure 15a).
5. Let the weight of the cone compress the mattress, but do not force the tool down onto the mattress or under the rail. Slide the tool towards the rail until it touches the rail or support (figure 15b).

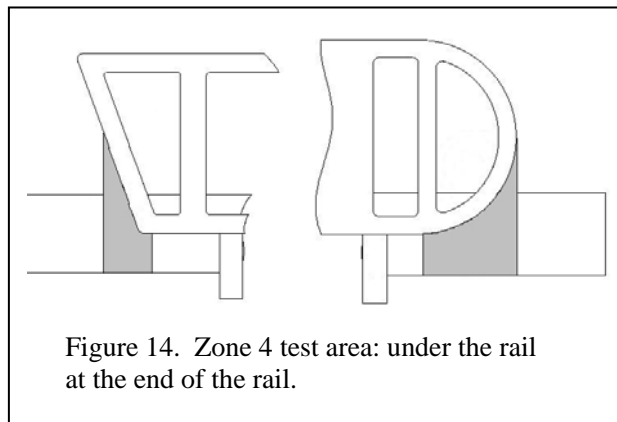

Figure 14. Zone 4 test area: under the rail at the end of the rail.

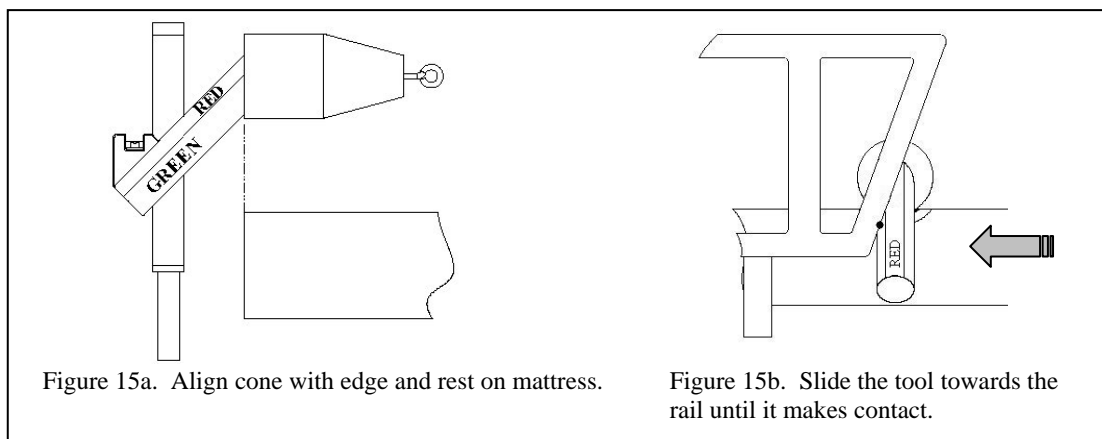

Figure 15a. Align cone with edge and rest on mattress.

Figure 15b. Slide the tool towards the rail until it makes contact.

6. Hold the cylinder section and use the level on the end of the cylinder to keep the cone level.

## Contains Nonbinding Recommendations

7. If the cylinder slides completely **under** the rail, this space **fails**. If the cylinder touches the rail, observe the color on the cylinder where it makes contact: Red **fails**; Green **passes** (figure 16).
8. Interpret test result.

### Interpret Zone 4 Test Results:

If the cylinder touches the rail in the **green** area, the space **passes** (figure 16a).

If the cylinder touches the rail in the **red** area, the space **fails** (figure 16b).

If the cylinder passes completely **under** the rail, the space **fails** (figure 16c).

Reminder: If the cylinder tool **cannot fit** into an area between the head or footboard and the end of a rail, the space **passes**.

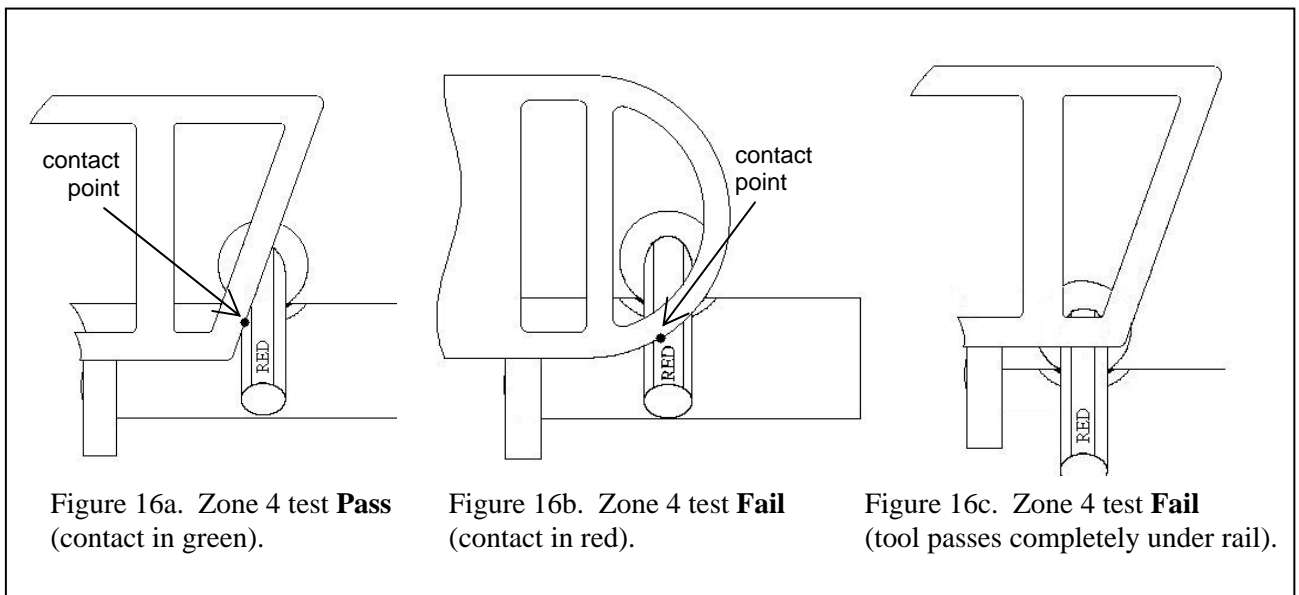

### Repeat the Zone 4 Test:

*On the same rail:* If the rail has any intermediate positions, perform the test at every intermediate position.

*On the other rails:* Perform the Zone 4 test at both ends of all other rails on the bed, including the intermediate positions.

## **Appendix to HBSW Dimensional Test Methods for Bed Systems Testing Tips and Frequent Questions**

### ***Do I have to do the tests in order?***

No. You may do the tests in any order you wish. You may find it convenient to do all the tests on one side of the bed, then the other (to keep from repeatedly pushing the mattress back and forth). Or, you may wish to do all of the tests that use just the cone, then all of the tests that use the cone and cylinder together (to avoid having to put the tool together and take it apart several times).

### ***Do I have to use the safety strap?***

The test tools are heavy, and the safety strap helps protect you if they fall or suddenly pull through a gap. Not using the safety strap increases your risk of being injured.

### ***How do I keep track of my test results?***

You may use any method that meets the recordkeeping requirements of your institution. HBSW has developed some sample data sheets that you may use or modify according to your needs. Sample data sheets are attached at the end of this document.

### ***What are the most common mistakes people make when doing the tests?***

In field tests conducted to evaluate the test tools and instructions, some of the most common errors made by the testers were:

- Not pushing the mattress away from the test location
- Pulling the mattress *toward* the test location (instead of pushing it away)
- Not articulating the bed enough to create the largest possible gap in Zone 2
- Not having the bed flat when testing Zones 1, 3, or 4
- Not aligning or leveling the tool properly
- Forcibly pushing the tool into gaps

### ***When pushing the mattress, how hard do I need to push?***

Some test instructions ask you to push the mattress "until it stops." Usually that means pushing until either:

- the mattress retention system (such as mattress stops, straps, or Velcro<sup>®</sup>) engages and keeps you from pushing the mattress any further, or
- the mattress stops against the opposite side rail(s).

Always make sure you push the mattress straight across; it should not be crooked on the bed.

### ***When testing Zone 2, what position should the bed be in?***

Unlike the other three tests, the Zone 2 test is not always done with the bed in the flat position. Before you do the Zone 2 test, you first need to find the correct testing position. With the bed in the flat position, identify the location of the Zone 2 space. Then, articulate the bed (adjust the head and knee sections) while you watch the Zone 2 space. As you articulate the bed, the Zone 2 space may get bigger, get smaller, or stay the same. Adjust the position of the bed until you find the position that makes the **largest** opening in Zone 2. If the size of the opening gets smaller, or does not change, return the bed to the flat position to do the test. Some examples of how Zone 2 might change with articulation are shown below.

## Contains Nonbinding Recommendations

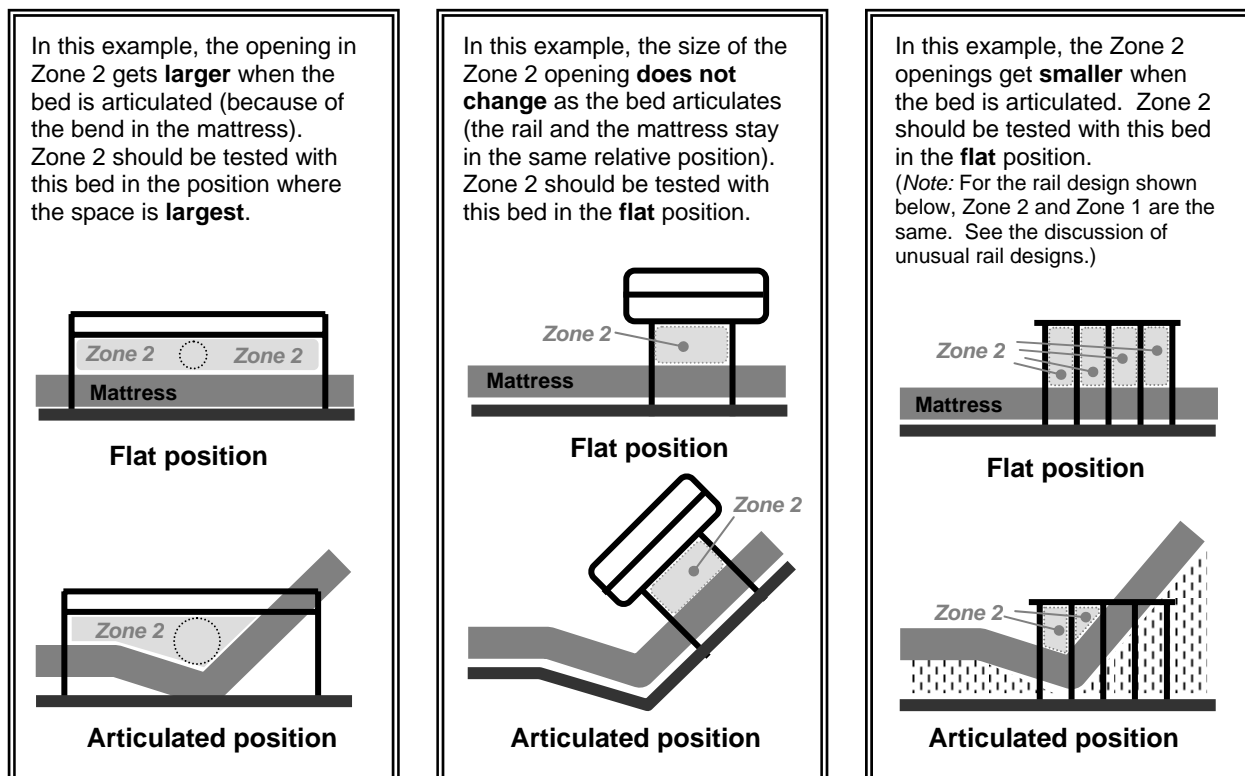

### *What if one of the Zones doesn't seem to exist on a particular bed system?*

If a zone doesn't exist on a particular bed, then there is no risk of a patient becoming trapped in that Zone. For example: if there are no openings in a rail, then a patient could not get his or her head trapped in Zone 1 of that rail. Your facility's policy and method of recordkeeping will determine how you should record data for Zones that do not exist. For example, your facility may use customized data sheets that simply omit zones or rails that do not exist. If you are using a generic form (such as a table or spreadsheet), it may be appropriate to record a result of either "pass," "not applicable," or "not tested," or to cross out entry spaces for Zones that do not exist. (You should provide some indication that the Zone was not accidentally omitted from testing.)

### *I need to test a bed with an unusual rail design. The rails don't look like any of the rails shown in the instructions or video. How do I figure out where to do each test?*

Occasionally, the most difficult part of a test may be figuring out where on the bed to perform the test. For some beds or rail configurations, it may be difficult to identify the locations of various Zones. The following hints and examples for each Zone may help.

**Zone 1:** The goal of the Zone 1 test is to see whether a patient could become trapped by putting his or her **head through** an opening in the rail itself.

#### Example: No openings in the rail

If there are no openings in the rail, then there is no risk of entrapment in Zone 1. Examples of cases where there may not be any openings in the rail are:

## Contains Nonbinding Recommendations

- The rail consists of a solid panel
- The rail has a cover on it, and the cover blocks all the openings in the rail (whether you can see through the cover or not).

**Zone 2:** The goal of the Zone 2 test is to see whether a patient could become trapped by putting his or her **head under** the rail, head first, between the rail supports (or next to a single support). (Note: Trapping the head by sliding the neck under the rail sideways is addressed by the test for Zone 4.)

### Example: Rail supports form part of the rail

In some designs, the rail supports also form part of the body of the rail. Crib-style rails, shown here, are common examples. Often, when the rail supports form part of the rail, Zones 1 and 2 overlap. Zone 1 should be tested with the bed in the flat position; if the size of the space changes with articulation, the result for Zone 2 may be different.

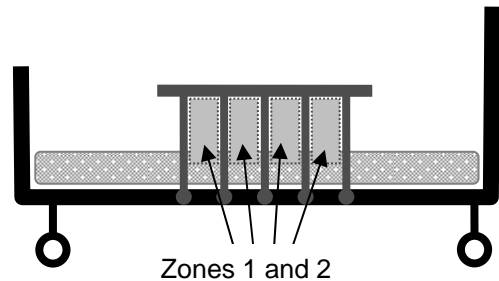

**Zone 3:** The goal of the Zone 3 test is to see whether a patient could become trapped with his or her **head in the horizontal space between** the rail and the mattress. Usually, the gap in Zone 3 is easily identified, even if the rail design is unusual.

**Zone 4:** The goal of the Zone 4 test is to see whether a patient could become trapped by sliding or wedging his or her **neck under** the end of the rail.

### Example: The rail end is very close to head/foot board (very little space in between)

When testing in Zone 4, do not try to force the cylinder down between the rail and the end board or insert it under the rail from behind. If the cylinder's diameter will not fit between the end of the rail and the head or foot board, record a result of Pass for Zone 4.

### Example: Full-length rail with horizontal supports at the ends

An example of this rail type is shown at the right. The cylinder cannot pass between the end of the rail and the head/foot board and then under the rail -- it would stop on the support. The result for Zone 4 is Pass, because a patient would not be able to get his or her neck under the rail without the head or body going under first. The potential for head-first entrapment under the rail should be evaluated using the test for Zone 2.

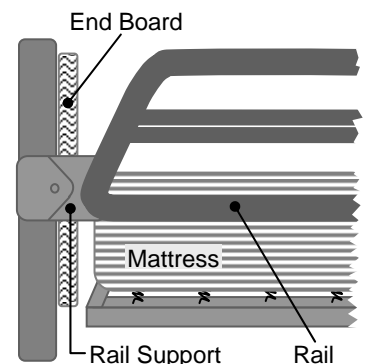

## Contains Nonbinding Recommendations

### Example: The end of the rail is vertical

When the end of the rail is completely vertical from top to bottom, there may be no space "under" the end of the rail where the cylinder (or a patient's neck) could fit. In the example at right, the left side of the rail is vertical, and there is no space "under" the end of the rail. For the left rail end in the figure, the rating for Zone 4 should be either "pass" or "not applicable," depending on your facility's policy. The right end should be tested as usual for Zone 4.

*Note:* If you are unsure about a particular rail you are testing, you should go ahead and perform the Zone 4 test to verify your answer. The cone and cylinder would give a result of Pass if they were used to physically test the area shown on the left side of the rail in the figure.

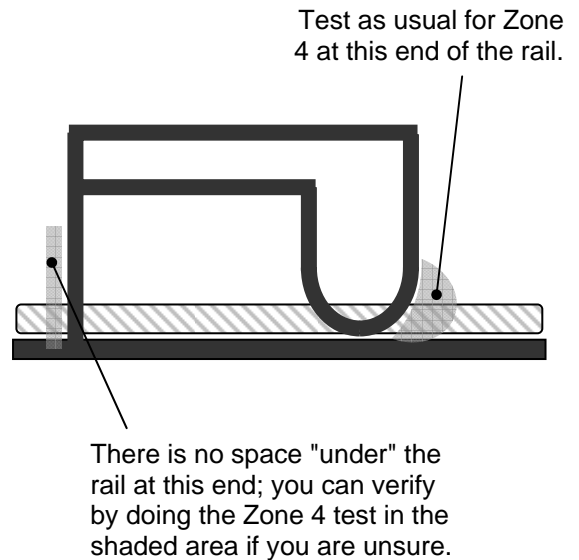

### ***Why did my co-worker and I get different results for the same test?***

Different testers can get different test results for the same bed system. Or, the same tester may get a different result when he or she repeats a test. Some reasons this can happen are:

- Different people may handle the tools slightly differently.
- An error or oversight can affect the test result (see common errors below).
- When a test is a very close call, some testers may be biased toward passing, and others toward failing.
- A long time has elapsed between tests (mattresses vary in softness, and can compress over time; rails or rail supports may loosen or bend over time).

### ***What if a result is too close to call?***

If you are faced with a borderline pass/fail decision, use your best judgment to decide on a result. You can also try these suggestions:

- Repeat the test, and double-check that you did every step correctly.
- If possible, get a second opinion. Ask a co-worker for help.

Your facility may also have suggestions or procedures for handling close calls. For beds with borderline passes that result from close calls, you may wish to consider mitigation (see the next question below).

## *Contains Nonbinding Recommendations*

### ***What should I do if a bed system fails one of the tests?***

You should strongly consider mitigation of entrapment risks for bed systems that fail any of the four tests. You may also wish to consider mitigation for bed systems that have borderline passes. Mitigation may include patient assessment; some patients are at lower risk for entrapment than others. For more information, consult the following, available at <http://www.fda.gov/cdrh/beds>:

- *Clinical Guidance for Assessment and Implementation of Bed Rails in Hospitals, Long Term Care Facilities and Home Care Settings*
- *A Guide for Modifying Bed Systems and Using Accessories to Reduce the Risk of Entrapment*

### ***What if I have a question that wasn't answered here?***

There are several resources available to help address questions. As a start, you may contact the supplier of your beds, mattresses, or rails. Your tool kit supplier is another resource. In addition, an advisory group is being established by the HBSW to address additional questions that arise. You may submit questions to that committee via the Web at [URL to be determined, [www.xxx.yyy](http://www.xxx.yyy)].





Contains Nonbinding Recommendations

