

Self-Inactivating LTRs & Chromatin Insulators

For the Prevention of Transcriptional Activation of Endogenous Genes by an Integrated Provirus

Philippe Leboulch
Harvard Medical School
Genetix Pharmaceuticals, Inc.
Presentation to FDA BRMAC 10/10/02

In Transduced Somatic Cells, the Vast Majority of Untoward Events of Insertional Mutagenesis Results From Enhancer-Mediated Cis-Activation by the Provirus

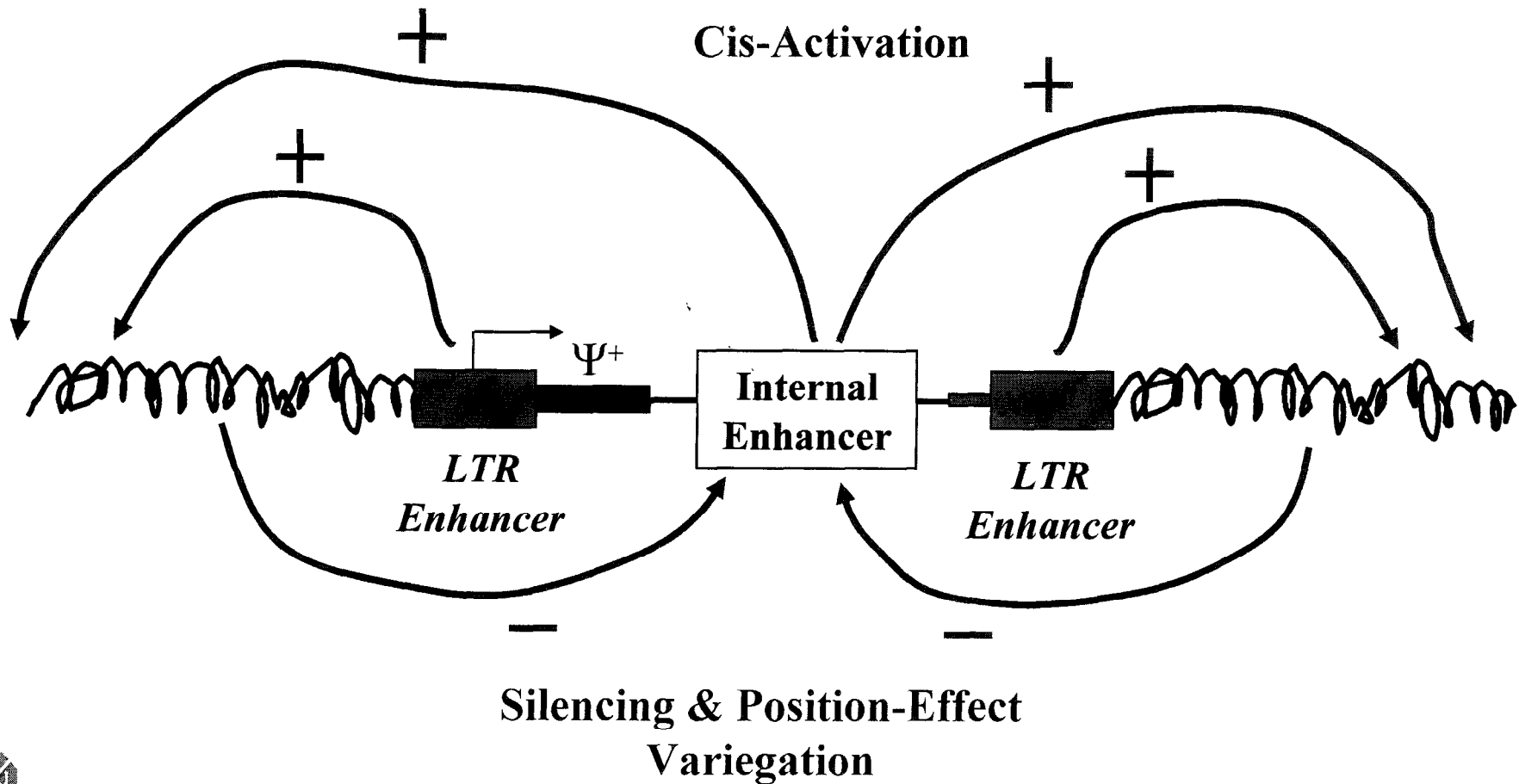

Design of Self-Inactivating Retroviral and Lentiviral Vectors To Eliminate the Enhancer/Promoter Activity of the LTRs

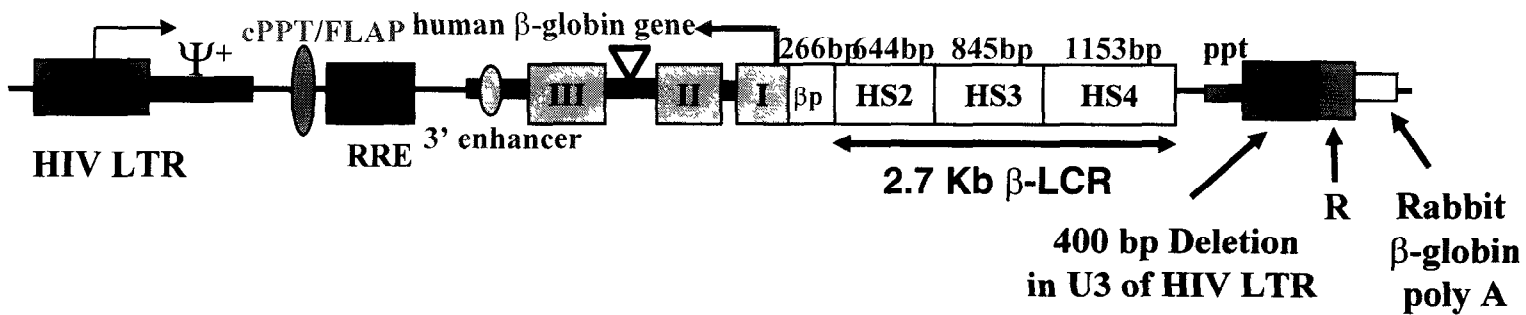

Reverse transcription
 &
 chromosomal integration

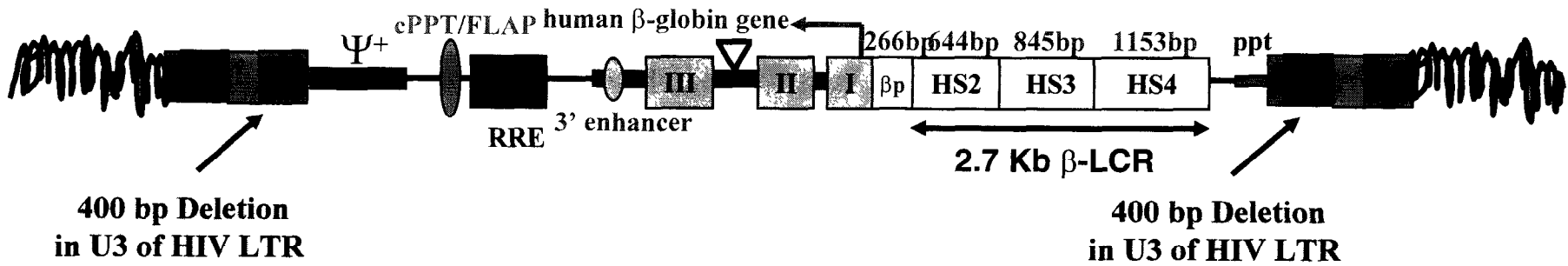

The Chicken cHS4 Insulator Blocks Enhancers from Activating Promoters (*G. Felsenfeld and coll.*)

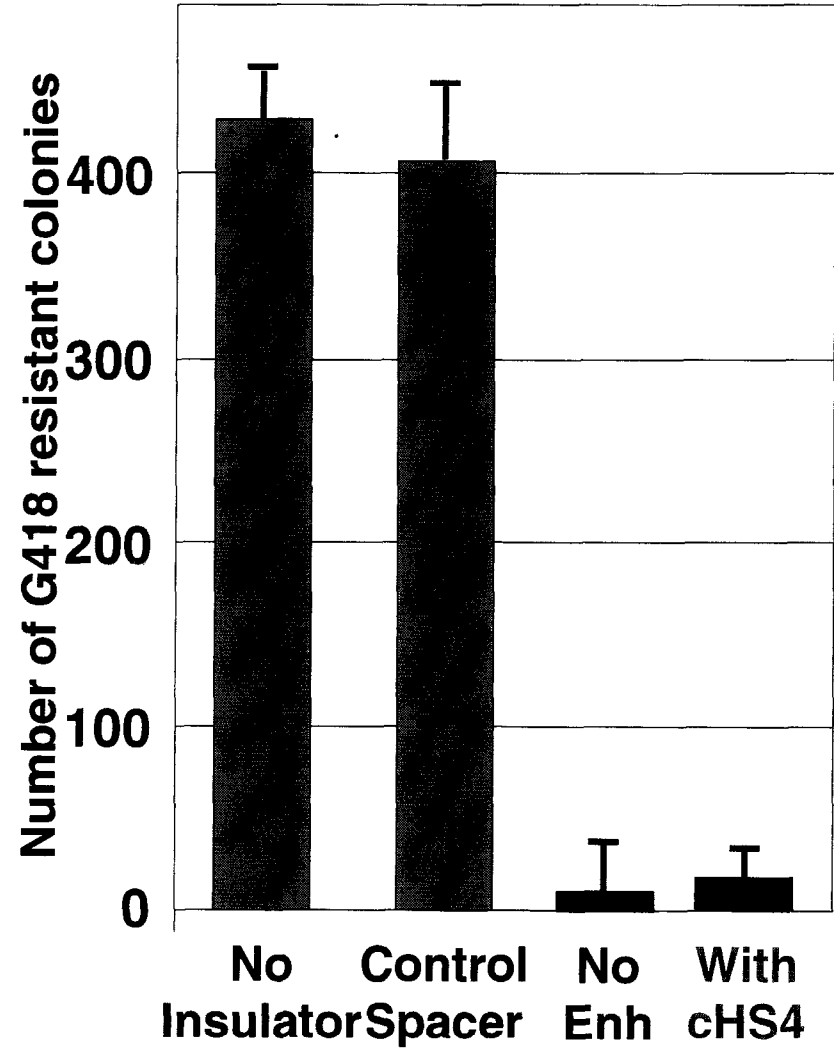
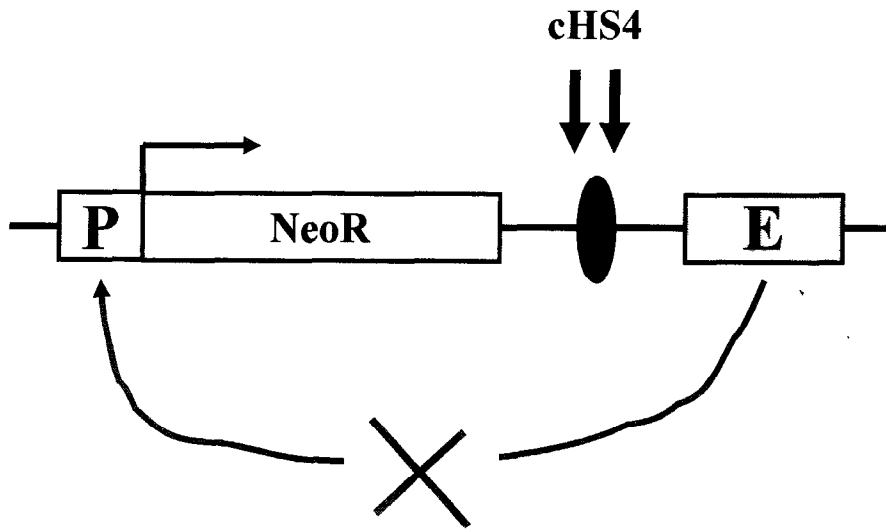

Retroviral LTRs Silence LCR/ β -Globin Constructs in Transgenic Mice

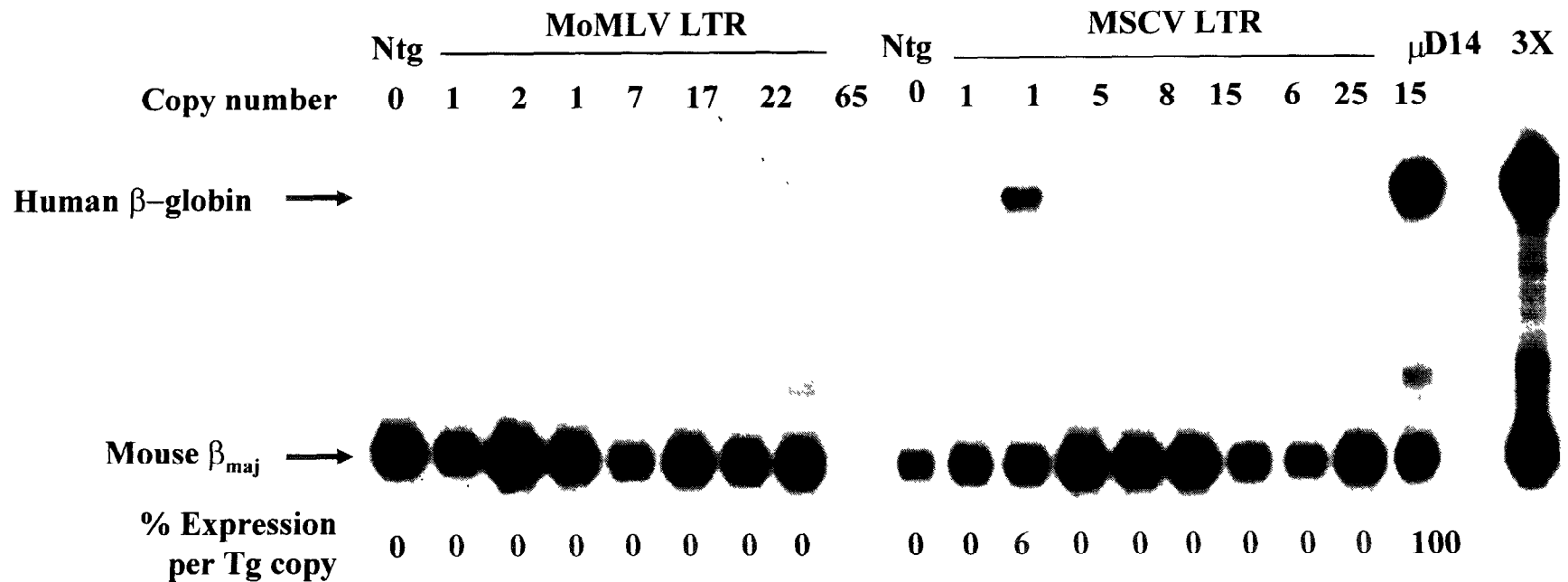
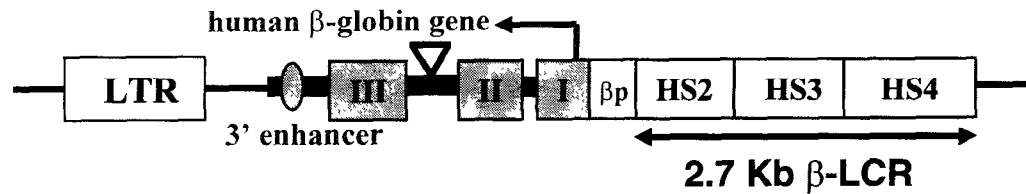

with permission from J. Ellis, Toronto



The cHS4 Insulator Blocks Retrovirus Silencing in Transgenic Mice

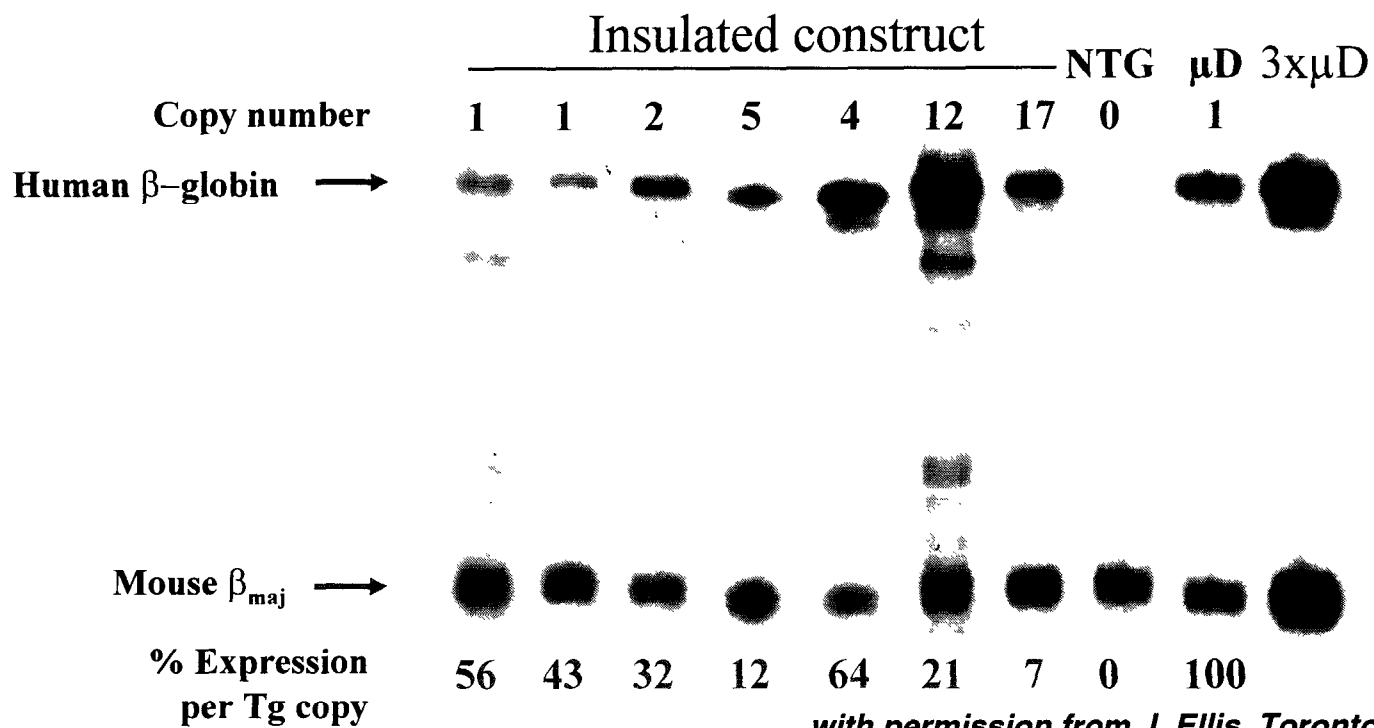
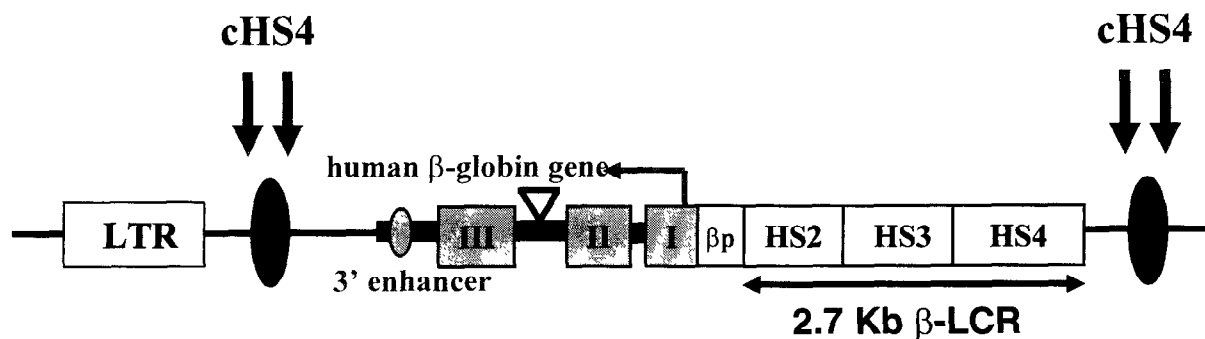

with permission from J. Ellis, Toronto



Establishing Provirus Boundaries with the cHS4 Insulator

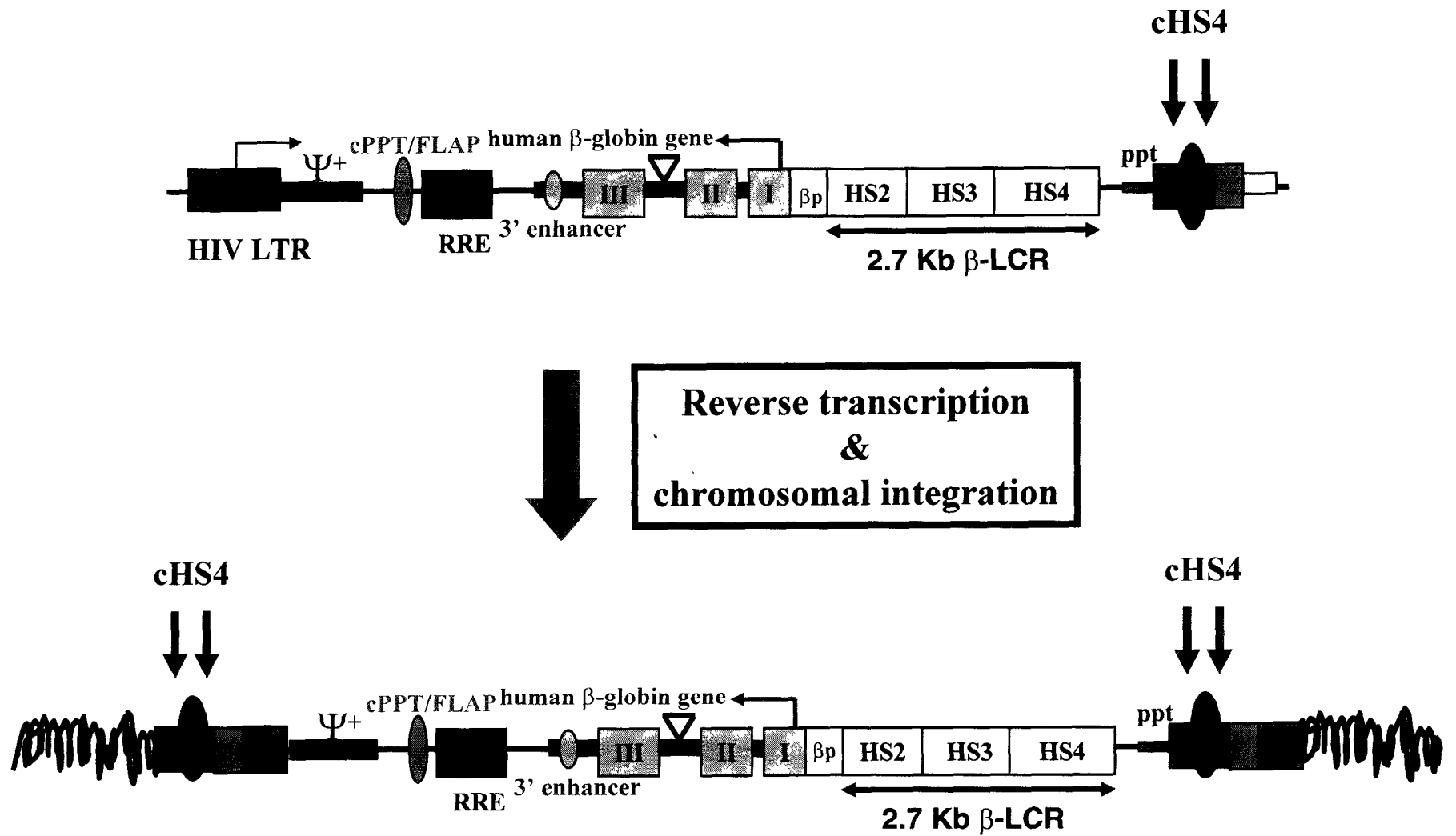

Stable, High-titer Transfer of cHS4 Insulators in Complex LCR/ β -Globin SIN Lentiviral Vectors

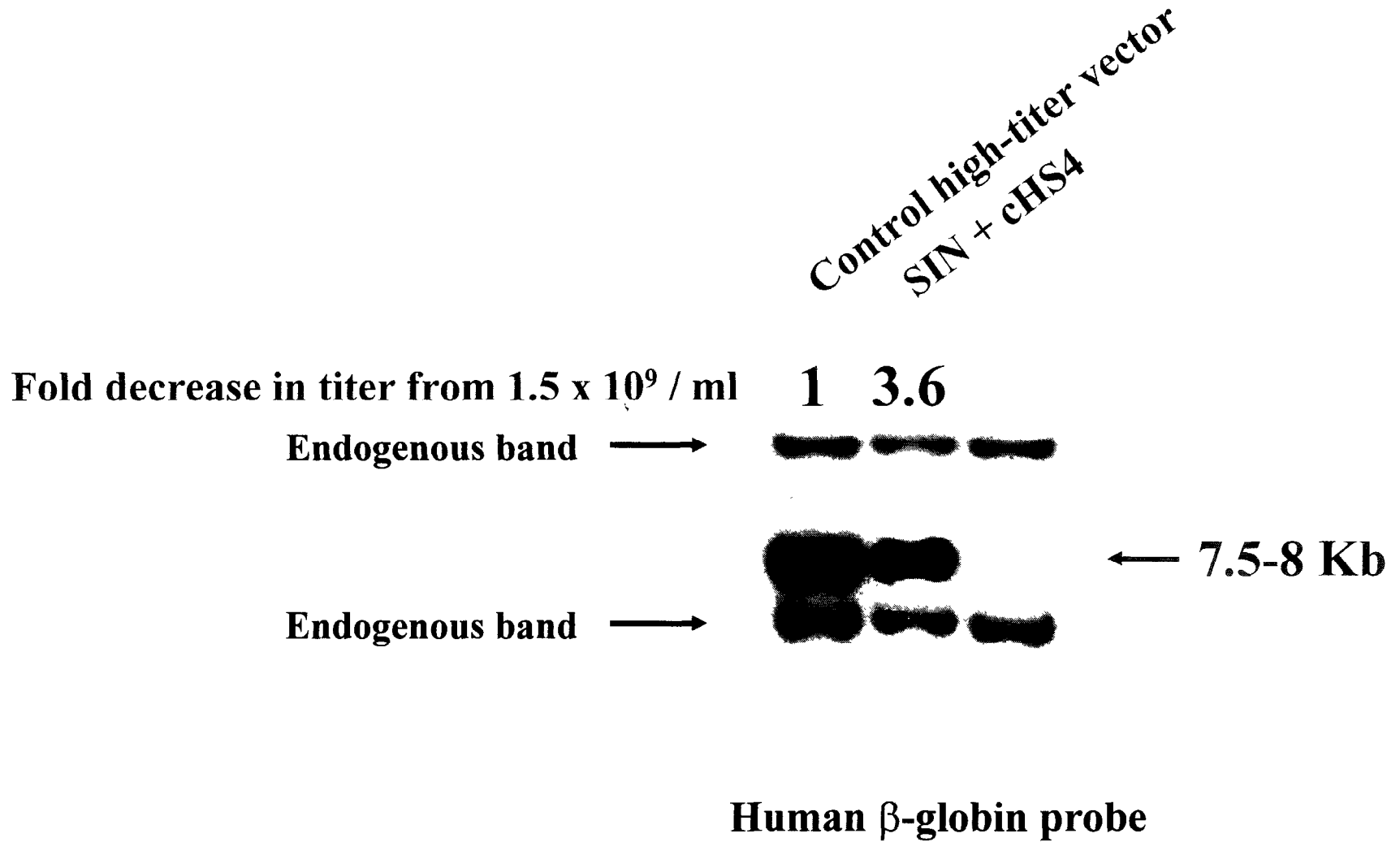

Resuming Gene Therapy Trials for X-SCID?

Construction of an Insulated MoMLV-Derived Retroviral Vector Expressing the Human γ c Chain

